

Table of Contents

1. Introduction.....	1-1
2. Glossary of Terms.....	2-2
3. General Warnings and Cautions	3-1
3.1. Contraindications for Pneumatic Compression Therapy:.....	3-1
3.2. Contraindications for Heat and Cold Therapy:.....	3-1
3.3. Precautions:.....	3-2
3.4. Warnings:.....	3-2
3.5. Cautions:.....	3-3
4. Indications for Use.....	4-1
5. VascuTherm Device Description.....	5-1
5.1. Features:.....	5-1
5.2. General Specifications:.....	5-1
5.3. Options:.....	5-1
5.4. Device Description:.....	5-2
6. Unpacking Your VascuTherm Therapy System.....	6-1
7. Environmental Conditions You Should be Aware of Before Operating Your VascuTherm Device.....	7-1
8. How to Set Up Your VascuTherm System for Therapy.....	8-1
9. Operating Instructions for Your VascuTherm System.....	9-1
9.1. Turning the Unit ON for the First Time:.....	9-1
Automatic Pre-Programmed Therapy.....	9-2
Manually Controlled Therapy.....	9-2
9.2. Cool Therapy:.....	9-3
9.3. Heat Therapy:.....	9-6
9.4. Thermal Contrast Therapy:.....	9-8
9.5. Pneumatic Compression Therapy for Edema and Lymphedema:.....	9-10
9.6. DVT Foot Compression Therapy:.....	9-13
9.7. DVT Calf Compression Therapy:.....	9-16
9.8. Pneumatic Compression Therapy and DVT Foot Therapy:.....	9-19
9.9. Pneumatic Compression Therapy and DVT Calf Therapy:.....	9-25
10. Display Messages and Alarm Indicators.....	10-1
10.1. Normal Operation.....	10-1
10.2. Warnings, Alarms, and System Errors.....	10-4
11. Things You Can Do To Keep Your VascuTherm System Performing.....	11-7
12. Draining the Fluid from the Unit.....	12-1
13. Storage and Re-Packing the Unit.....	13-1
14. Troubleshooting Guide.....	14-1
15. Device Summary.....	15-1
16. Service and Customer Support.....	16-1
17. Wraps, Accessories and Replacement Parts.....	17-1
18. Specifications.....	18-1
18.1 Calibration.....	18-1

18.2 Product Listing.....	18-1
19. Index	19-1
20. Warranty and Disclaimer Information.....	20-1

1. Introduction

Please read the entire manual carefully before trying to operate the VascuTherm™ system. It is unsafe to start using the VascuTherm system before reading the entire user manual.

At ThermoTek, we pledge to provide the highest quality product with excellent support and service. If we can do anything to make your VascuTherm experience better, please do not hesitate to contact us.





User Assistance Information:

The VascuTherm Therapy System is manufactured by:

ThermoTek, Inc.
1200 Lakeside Parkway #200
Flower Mound, TX 75028
(972) 874-4949
(877) 242-3232 (toll free service number)

For 24-hour Service, call (214) 502-8800
or visit us on the web at www.thermotekusa.com

Icons Used for Warnings and Cautions:

-  Electrical Shock Risk
-  Burn Risk
-  Frostbite or Cryogenic Burn Risk
-  General Caution



Do not drink or ingest the coolant mixture.

In the event of a Medical Emergency, call:

9-1-1

2. Glossary of Terms

Arterial Dysregulation – a physiological impairment of the arteries.

Arteriosclerosis – a chronic disease in which thickening, hardening, and loss of elasticity of the arterial walls result in impaired blood circulation.

Constant Compression – continuous and regulated compressive force applied to the skin surface for the manipulation of subcutaneous compartment pressures.

Carcinoma Metastasis – a malignant new growth having potential to spread.

Contraindication - a reason that makes it inadvisable to prescribe a particular drug or employ a particular procedure or treatment to a patient.

Contrast – a pain management therapy consisting of repeatedly heating and cooling of the subcutaneous muscle tissue.

Deep Venous Thrombosis (DVT) - a type of phlebothrombosis; the formation of a clot in the deep veins of the extremities typically due to slowing or halting of blood return to the heart.

Edema – an accumulation of an excessive amount of watery fluid or blood in cells, tissues, or serous cavities of the body.

Erysipelas – an acute superficial form of cellulitis; a spreading inflammation of subcutaneous or connective tissue.

Hypertonia – extreme tension of the muscles or arteries

Non-Ambulatory – to be in a resting or immobile state; not moving.

Phlebothrombosis – thrombosis of a vein without prior inflammation of the vein; associated with sluggish blood flow or with rapid coagulation of the blood. Usually caused by prolonged bed-rest, pregnancy, or surgery.

Pulsating Compression – also called intermittent or undulating compression is the manipulation of subcutaneous compartment pressures in a high-to-low repeating cycle.

Stasis Dermatitis - a common inflammatory skin disease that occurs on the lower extremities in patients with chronic venous insufficiency with venous hypertension.

Thrombophlebitis – an acute inflammatory reaction of a vein due to thrombus presence.

Thrombus - a clot formed in a blood vessel or in a chamber of the heart.

Vein Ligation – the presence of veins that have been surgically rejoined.

Venous Stasis – slowing of blood flow typically caused by venous valve failure or the existence of clots in the vein.

3. General Warnings and Cautions

3.1. Contraindications for Pneumatic Compression Therapy:

The patient should **NOT** use the VascuTherm therapy system if the patient is suspected of or observed to have any of the following:

- Presumptive evidence of Congestive Heart Failure,
- Pre-existing DVT Condition,
- Deep Acute Venal Thrombosis (Phlebothrombosis),
- Inflammatory Phlebitis Process,
- Episodes of Pulmonary Embolism
- Pulmonary Edema,
- Acute Inflammations of the Veins (Thrombophlebitis),
- Decompensated Cardiac Insufficiency,
- Arterial Dysregulation,
- Erysipelas,
- Carcinoma and Carcinoma Metastasis in the Affected Extremity,
- Decompensated Hypertonia,
- Acute Inflammatory Skin Diseases or Infection,
- Venous or Arterial Occlusive Disease,
- Venous or Lymphatic Return is Undesirable,
- Poor Peripheral Circulation,
- Severe Arteriosclerosis, or active infection

3.2. Contraindications for Heat and Cold Therapy:





















The following patients must use the VascuTherm therapy system for temperature contact therapy under the supervision of a physician if they are:

- Individuals with Extremities not Sensitive to Pain,
- Individuals with Extremely Low Blood Pressure,
- Individuals with Raynaud's Disease,
- Hypersensitive to Cold,
- Children,
- Diabetics,
- Incapacitated Patients,
- Individuals with Decreased Skin Sensitivity,
- Individuals with Poor Circulation,
- Patients with Vein Ligation or recent Skin Grafts.

















3.3. Precautions:









When using the VascuTherm system, basic safety precautions should always be followed to reduce the risk of fire, electric shock and personal injury. Please read the entire manual carefully before trying to operate the unit. Precautions include:

3.4. Warnings:

-  Never push objects of any kind into the therapy unit through the air filter or frame.
-  Never spill liquid of any kind on the therapy unit.
-  Do not overfill the reservoir of the unit.
-  If the unit gets wet, unplug the unit from the wall and allow the unit to dry before use.
-  The unit must be operated with the supplied power cord and plugged into a 3-prong grounded outlet.
-  Do not operate the unit if it has any noticeable or physical damage or is leaking fluid.
-  Do not operate the unit with a damaged or frayed power cord.
-  The therapy unit is not intended to be used in a wet environment or when relative humidity is greater than 60%.
-  Do not spray the unit with any water solvents or cleaners.
-  Do not drop the therapy unit or cause impact to the unit.
-  Do not pull or otherwise put undue stress on the hoses.
-  Do not use this device without the supplied air filter.
-  Do not use near equipment that generates electromagnetic or other interferences as this may be harmful to the therapy unit.
-  Do not smoke while use therapy wraps or use wraps by an open flame.
-   Do not touch the heat sink fins on the sides of the unit during or immediately after operation.
-    Do not stick a finger or any other foreign objects into the reservoir.
-  **Do not drink or ingest the coolant.**

3.5. Cautions:

-  If unusual swelling, skin discoloration or discomfort occurs, immediately discontinue use of the VascuTherm unit and consult a healthcare professional.
-  Use only ThermoTek approved therapy wraps.
-  Therapy wraps are non-sterile unless specifically labeled as sterile
-  Non-sterile therapy wraps should never be directly applied to an open wound or breached skin.
-  Use only sterile wraps over wounds or breaks in the skin.
-  Do not attempt to sterilize this device by any means.
-  A licensed healthcare practitioner must select the correct temperature setting for hot or cold therapy use.
-  Patients vary in sensitivity to cold. Make a regular check of the patient's temperature once established.
-  Follow the prescribed instructions of your physician for area, frequency and duration of treatment.
-  Therapy wraps are to be fitted initially by a healthcare professional that is familiar with the purpose for which the wraps are used.
-  Do not apply the therapy wrap so tightly as to restrict blood or fluid flow.
-  A healthcare professional is responsible for providing wearing instructions and precautions to other healthcare professionals, care providers involved in the patient's care, and the patient.
-  If it is appropriate for the patient to use the wrap with therapy unit at home, the healthcare provider must provide adequate and appropriate instructions for use to the patient.
-  The healthcare provider must monitor the patient's use of the therapy unit, assuring appropriate use and application of all therapies.
-  Disposable therapy wraps are designed for single patient use only and may only be used on the same patient for the length of the treatment.
-  The therapy wrap should be periodically cleaned if it is used on the same patient for an extended period of time.

-  Clean exposed surfaces of the therapy wrap with either a mild anti-bacterial soap and water solution or an isopropyl alcohol and water solution. Do not use bleach on therapy wraps.
-  Dressings used under the therapy wrap should be applied lightly.
-  Do not use pins to secure the therapy wraps or hoses.
-  Do not allow the therapy wrap or hoses to contact sharp objects that could puncture it.
-  All therapies using compression must be turned OFF when the unit is not in use or the wrap is removed from the patient for prolonged periods or for repositioning of the wrap.
-  Immediately stop compression therapy if you experience any sense of discomfort, numbness or tingling of the limb.
-  Use only the approved coolant in the VascuTherm unit.
-  Slots and openings in the cabinet are provided for ventilation to protect the unit from overheating. These openings must not be blocked or covered at any time except by the supplied air filter.
-  Observe all warning labels. Never remove the warning labels.

4. Indications for Use

The VascuTherm therapy system is designed to provide fluid heating, cooling and compression as specified in this manual. If the system is used in a manner other than as specified, its operation or the safety protection may be impaired.

Indications for use are to:

- Treatment of disorders associated with vascular or lymphatic insufficiency such as Chronic Venous Insufficiency (CVI), venous stasis ulcers, post-mastectomy edema and chronic lymphedema,
- Reduction of edema associated with soft tissue injuries such as burns, postoperative edema, and ligament sprains,
- Localized thermal therapy (hot or cold) for post traumatic and post surgical medical and/or surgical conditions,
- Decrease the risk of deep venous thrombosis (DVT),
- Aids the blood flow back to the heart,
- Treat and assist healing of cutaneous ulceration (wounds), reduce healing time, enhance arterial circulation (blood flow), reduce compartmental pressures, reduce edema (swelling), reduce the need for anticoagulant (blood thinning) medications.

5. VascuTherm Device Description

The VascuTherm therapy system is an electronic heating, cooling and compression system. The VascuTherm therapy system provides precisely controlled hot or cold fluid that never has to directly contact the skin during therapy. The system is also capable of providing calibrated compressed air all in one convenient unit. This lightweight, portable system utilizes solid-state thermoelectric heat pumps that heat and cool with electricity in a safe and environmentally friendly manner.

5.1. Features:

- Fluid Therapy Temperature Range between 43° F – 50° F to 105°F
- Compression Modality to Reduce the Risk of DVT Formation on the Calf (45mmHg compression) and Foot (100 mmHg compression)
- Treatment for Edema and Lymphedema in the Upper and Lower Extremities with alternating compression from 10 mmHg to 30 mmHg
- Pain Management
- Programmable Therapies
- Lightweight and Portable Package
- User-Friendly Interface
- 110 VAC Power Input
- Illuminated Fluid Level Indication
- Easy to read Liquid Crystal Display
- Quiet Operation

5.2. General Specifications:

- Weight: 15 lbs.
- Hose Length: 7 ft.
- Hospital Grade Power Cord
- Dimensions: 5.25”W x 8.75”H x 14.25”D
- Operating Fluid: 90% Distilled Water/10% Isopropyl Alcohol
- Safety: UL Medical Listing 60601

5.3. Options:

- Sterile Single Patient Use Therapy Wraps
- Non-Sterile Single Patient Use Therapy Wraps
- Bed Hooks
- Carrying Case
- Rolling Stand

5.4. Device Description:

Rear Panel Connections

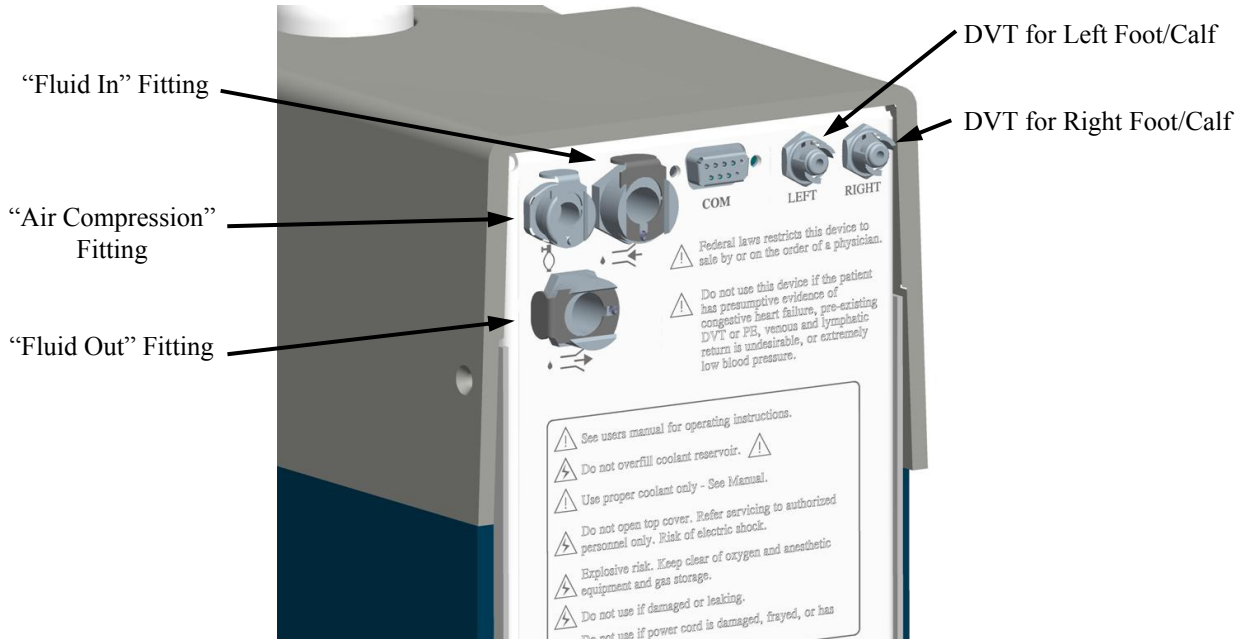

Coolant Reservoir Fill Location

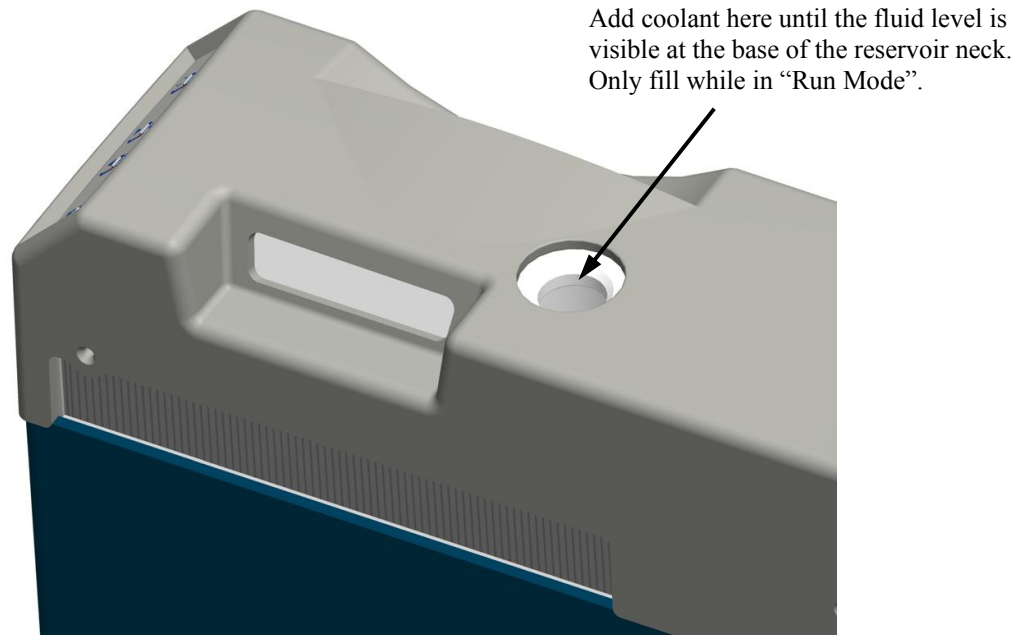

Reservoir Coolant Level Window

If the coolant level can be seen lower than halfway down the window, more coolant should be added.

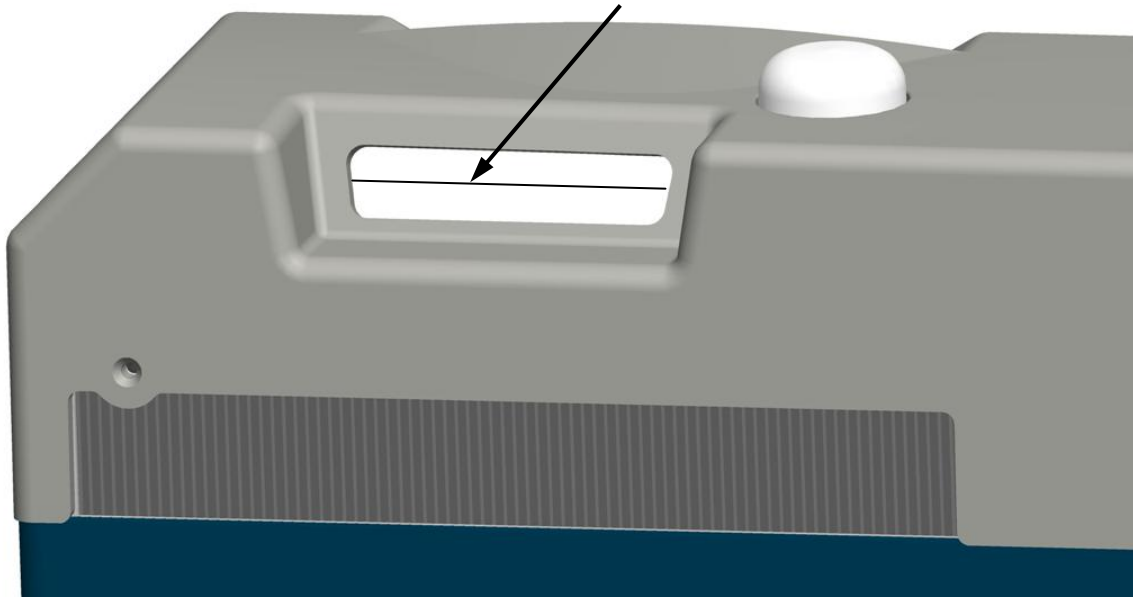

Keypad Interface and Illuminated Display

Display Indicator Window

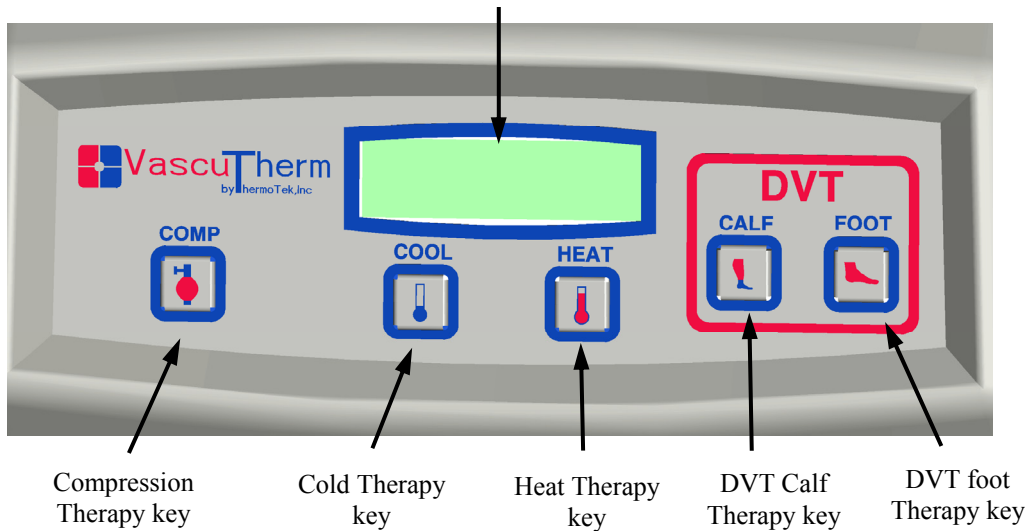

6. Unpacking Your VascuTherm Therapy System



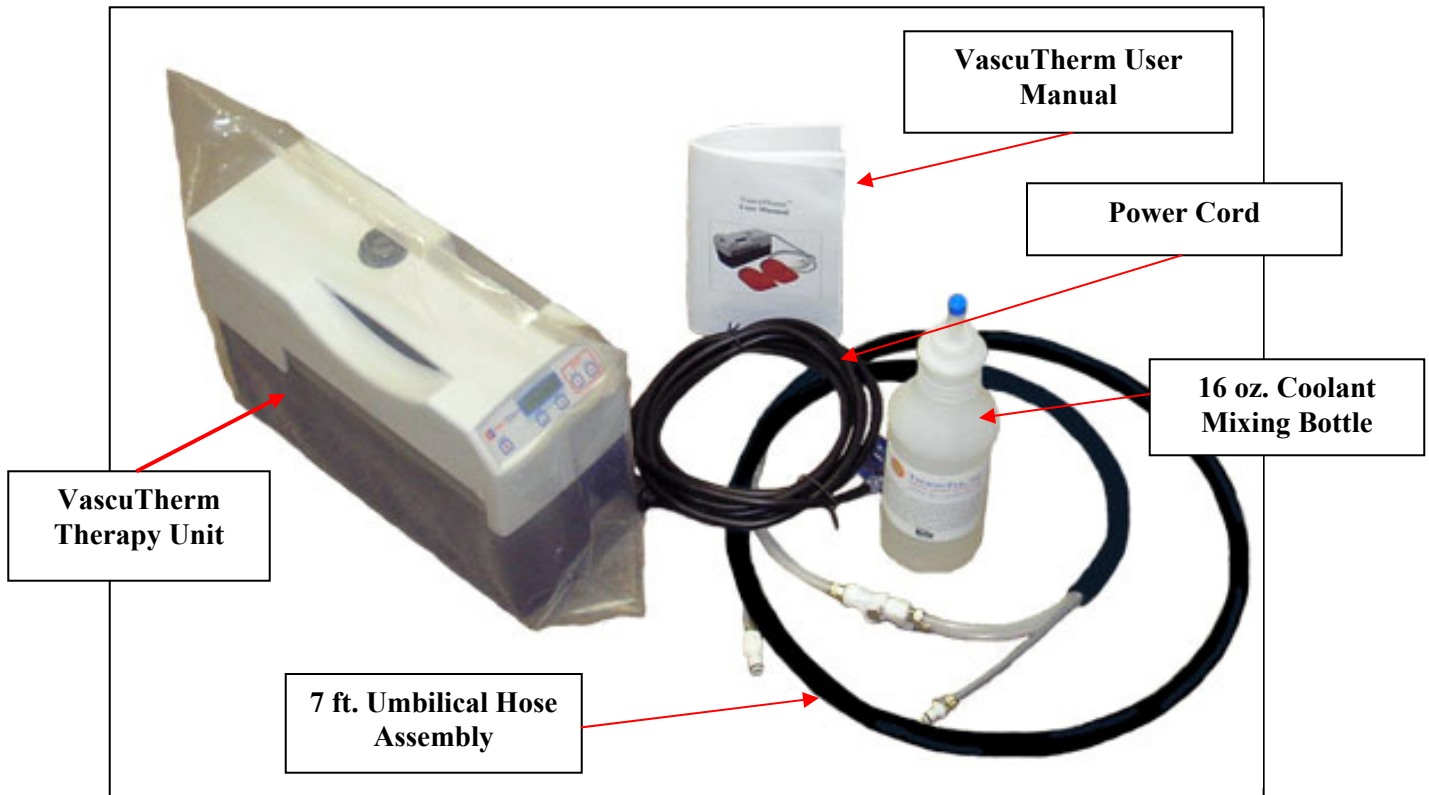

When you first unpack the carrying case you should have the following items:



All of these items are needed for safe system operation. If any of these items are missing from the carrying case or shipping container, please contact the clinic or hospital that prescribed the unit, the Durable Medical Equipment (DME) provider or ThermoTek Customer Service at 877-242-3232.

Immediately upon unpacking your VascuTherm Therapy System, inspect your unit. If the unit shows shipping damage, contact the transportation company and file a freight damage claim. **Be sure to retain all packing material and the original box or case.**



Along with the VascuTherm Therapy System you should have received all therapy wraps necessary for your prescribed treatment in individually sealed, unopened bags. These wraps may be marked “Sterile” or “Non-Sterile” depending on the type of treatment recommended by your physician.

- Disposable therapy wraps are designed for single patient use only. If you received a therapy wrap in a non-sealed bag or container, the wrap should not be used.
-  Please contact the clinic or hospital that prescribed the unit or the Durable Medical Equipment (DME) provider immediately to obtain a new, sealed therapy wrap.
 -  Non-sterile therapy wraps should never be directly applied to an open wound or breached skin.
 -  Use only sterile wraps over wounds or breaks in the skin.
 -  Disposable therapy wraps are designed for single patient use only and may only be used on the same patient for the length of the treatment.

7. Environmental Conditions You Should be Aware of Before Operating Your VascuTherm Device

 The VascuTherm therapy system is intended for indoor use only.



 Do not operate the VascuTherm system with therapy wraps in or near a wet environment.

  The VascuTherm therapy system is not to be used in a confined space. Adequate air flow distance from the unit sides must be maintained during operation. Inadequate air flow can result in overheating of internal electrical components and undesirable or excessive noise.

Only use the VascuTherm system in an ambient environment between 60-80 °F (degrees Fahrenheit) and a relative humidity below 60%.

Failure to meet these operating environment conditions may result in:

 Condensate buildup inside the unit.

   Overheating or freezing of the unit.

 Internal electronics malfunction

- A reduction in the heating or cooling capabilities of the unit
- A potential to blow the unit's electrical fuse due to an internal electrical overload.
- The inability of the unit to properly regulate and administer fluid temperature during heat or cold therapies.
- The inability of the unit to properly regulate and administer pneumatic compression as specified in the indications for use.

8. How to Set Up Your VascuTherm System for Therapy

Now that you have fully unpacked your VascuTherm Therapy System and verified that all of the necessary equipment is present and not damaged, you may begin to prepare the system for treatment.

1. Place the VascuTherm unit upright on a level surface and at least 1-foot from any wall or other obstruction that could restrict airflow through the air filter.
2. Verify that the power switch located on the rear panel of the unit is in the OFF position.



If you were prescribed DVT Prevention Therapy Only: follow steps 3-6. For all other therapies, skip to step 7.

3. Unpack and apply the prescribed therapy wraps to the indicated portions of your body as described on the wrap instructions contained in the wrap packaging.
4. On the rear panel of the unit, locate the fittings marked “Left” and “Right”.
5. To attach and secure the therapy wrap fittings, insert the wrap fitting into the rear panel connector and twist ¼-turn clockwise to lock. Do this for both the Left and Right wraps.





6. Plug the supplied power cord into the unit and into a 110-volt outlet. The VascuTherm therapy system is now ready for DVT prevention therapy. Refer to the Operation Instructions in Chapters 9.6 for FOOT treatment or 9.7 for CALF treatment.

For Heat, Cool, Lymphedema, or Edema Treatment Only:

7. Unscrew and remove the coolant reservoir plug from the top of the unit. Using the coolant bottle supplied with the therapy system, fill the reservoir to the bottom of the reservoir neck. See the coolant mixing instructions label located on the coolant bottle.
8. Unpack a prescribed therapy wrap and place the wrap flat on a surface lower than the VascuTherm unit.
9. Connect the clear and grey hoses to the therapy wrap used for treatment. The fittings should make a “click” sound when inserted to indicate a secure connection.
10. On the rear panel of the unit, locate the fittings marked by the symbols  for “Fluid Out”,  for “Fluid In”, and  for “Air Compression”.



11. Connect the clear hoses to the  and  ports on the rear panel of the unit (flow direction does not matter on this unit). The fittings should make a “click” sound when inserted to indicate a secure connection.
12. Connect the grey hose to the  port. The fitting should make a “click” sound when inserted to indicate a secure connection.
13. Plug the supplied power cord into the unit and into a 110-volt outlet.
14. Turn on the unit. The power switch is located on the rear panel of the unit. When first powered up, the unit will beep briefly and a green light will illuminate the display screen.

15. After a brief boot-up sequence, the display will show the status screen:

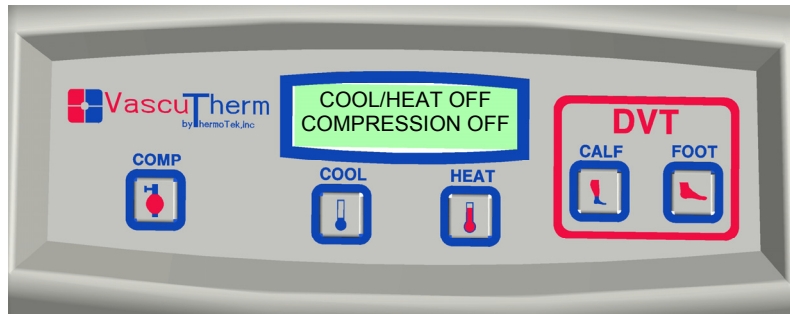

16. Press and hold the **COOL** key to begin priming the pump and filling the wrap.

17. Check the coolant level in the reservoir periodically over a 3-minute priming period and add coolant to the reservoir as necessary. If a “Check Flow/Fluid” alarm shows on the display, press and hold the **COOL** key to stop and start the priming process.

18. Screw the plug into the reservoir. The VascuTherm therapy system is now ready for therapy. Refer to the Operation Instructions in the next chapter for details on your specific prescribed treatment.

If you experience difficulty in setting up your VascuTherm therapy system for use, please contact the clinic or hospital that prescribed the unit or the Durable Medical Equipment (DME) provider. If assistance is not available or is ineffective, please contact ThermoTek technical assistance toll-free at 1-877-242-3232 during the hours of 8am-5pm Central Time. If technical assistance is needed after these hours, you may contact the 24-hour line at (214) 502-8800.

9. Operating Instructions for Your VascuTherm System

Refer to Chapter 8 “How to Set Up Your VascuTherm System for Therapy” before beginning any therapy.



The patient **MUST** be familiar with all warnings and cautions listed in Chapter 3 before attempting to operate the unit.



The wraps for the VascuTherm system are designed to maximize the effectiveness of the therapies listed above. Only use wraps in combination with therapy modes as prescribed.

The VascuTherm Therapy System is capable of performing therapies for the following:

- Cool Therapy,
- Heat Therapy,
- Thermal Contrast Therapy
- Pneumatic Compression Therapy for Edema and Lymphedema, and
- Pneumatic Compression Therapy for the prevention of DVT and PE.

9.1. Turning the Unit ON for the First Time:

The VascuTherm therapy system is capable of being programmed with a specific prescribed therapy by the equipment provider. Your therapy unit may have been programmed in such a manner or may be intended to be used with manually initiated therapies. To set up the unit for therapy, follow the instructions below.

1. Turn on the unit. The power switch is located on the rear panel of the unit.
2. When first powered up, the unit will beep briefly and a green light will illuminate the display screen.
3. After a brief boot-up sequence, the display will read one of two screens:
 - a. If the unit was pre-programmed by the equipment provider, the screen will display “Therapy Setting TIMER H: MM” and automatically begin therapy for the prescribed amount of time indicated on the therapy timer.

- b. If the unit was not pre-programmed and is intended for manual therapy, VascuTherm will go into Standby mode. The display will show the Status screen. The top display line shows the status of the Thermal subsystem, while the bottom display line shows the status of the Pneumatic subsystem.

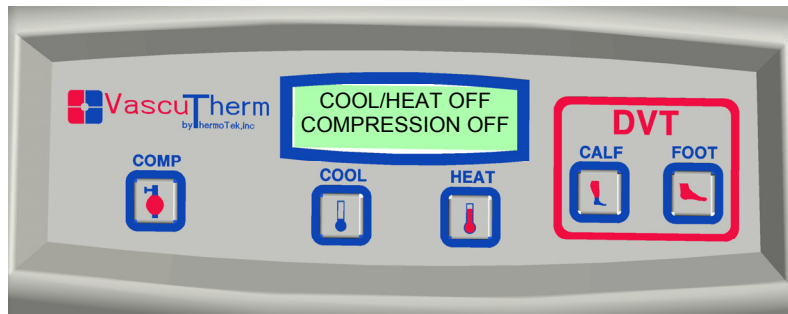

Automatic Pre-Programmed Therapy

After the initial “Therapy Setting TIMER H:MM” screen the display will scroll back and forth between the current therapy setting and the time remaining in the treatment cycle. When the therapy timer expires, the unit will beep briefly, automatically stop and go into a stand-by mode.

At any time during the automatic therapy mode the **COMP** key (for Edema or Lymphedema) or appropriate **DVT** key (for DVT and PE) can be tapped to display the current compression system setting. If the **COMP** key is tapped again, the current real-time air pressure in the wrap will be displayed. If in use, you can also tap the **COOL** or **HEAT** keys to display the current, real-time temperature of the coolant.

DO NOT press and hold any of the keys during automatic therapy. Doing so will halt the automatic therapy timer and change the unit into manual mode. The unit will notify you of a mode change by a sustained audible beep. If you happen to change the unit from automatic to manual mode, you must turn the unit off at the rear panel switch and back on again to restart automatic therapy and the therapy timer. Any therapy time used on the timer will not be retained and therapy must restart from the beginning to ensure proper treatment.

The set temperature may be pre-programmed. If the set temperature is pre-programmed, you will not have the option to change the set temperature during cool therapy.

Manually Controlled Therapy

Instructions on how to control the unit manually are detailed in the following chapters 9.2 to 9.7.

9.2. Cool Therapy:

Cool Therapy passes cool fluid through the wrap for the management of pain, discomfort and swelling. If prescribed, Cool therapy can be used in combination with Pneumatic Compression therapy (see the instructions in Chapter 9.4).

1. To initiate Cool Therapy, press and hold the **COOL** key on the display for at least one (1) second. The display will change and now read “Therapy Set XX° F”. XX is the preset cool therapy temperature in 43-50 °F range. Therapy will begin and automatically cool the wrap to the preset temperature.

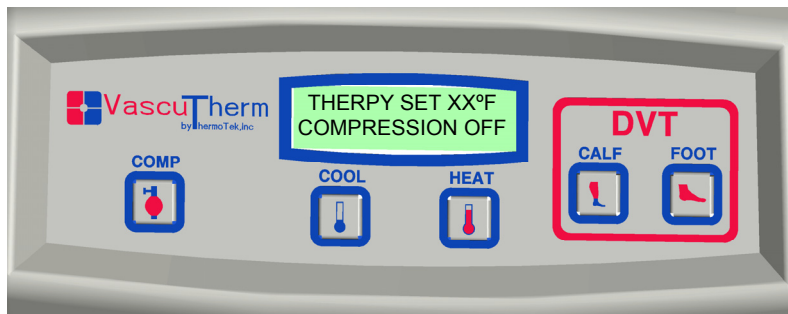

Note: If the desired key is not held for one second or more, the display will read “Hold Key for 1 sec to Start”.

2. At any time during treatment you can tap the **COOL** key to display the current therapy temperature.

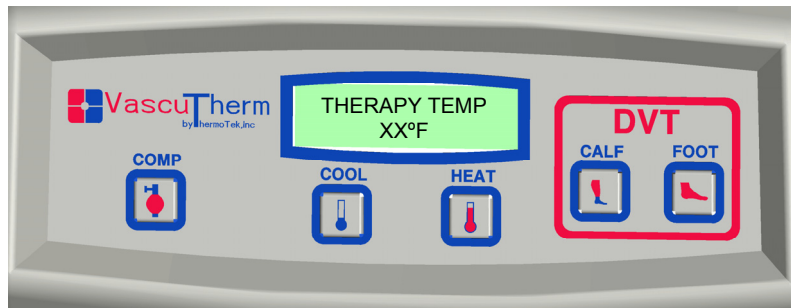

3. If the **COOL** key is tapped again, the display will read:

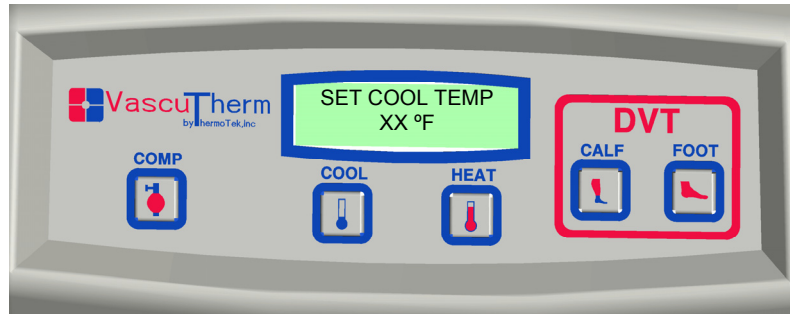

Note: This option will not be available if the set temperature is pre-programmed.

4. Cool Therapy Set temperature could be modified by tapping the **COOL** key. Set Temperature is adjustable in 43 – 50 °F. It will be reduced by 1 °F with every **COOL** key tap. If the value is 43 °F, Set Temperature will wrap back to 50 °F.

Note: VascuTherm will remember the cool temperature setting and use it when the next cool therapy is initiated.

Note: After ten seconds, the display will automatically go back to the Status screen.

When the prescribed therapy duration is complete:

5. Press and hold the **COOL** key for at least one second. The therapy will stop and the display will return to the Status screen.
6. If times between treatments are more than one hour, it is recommended to turn the unit OFF to prevent condensation from building up on the therapy wrap.

If continuous daily treatments are prescribed, it is best to leave the unit:

- Turned ON,
- Connected to the therapy wrap, and
- Controlling to the desired temperature, and
- Compression turned OFF.



Compression should be turned OFF when the therapy wrap is not on the patient. Allowing the wrap to inflate while unattended or to inflate all the way to a “ballooned” state can cause damage to the wrap and will reduce the life of the wrap.



If Compression therapy is being used in combination with Cool therapy, allow the wrap to fully deflate before removing it from the patient.

Note: Condensation time may vary based on the operating environment. Condensation time may be shorter for extremely cool environments. Watch for condensation build-up on the wraps during cool therapy. If condensation forms, remove condensation from therapy wraps with a clean, dry cloth prior to patient use.

9.3. Heat Therapy:

Heat Therapy passes warm fluid through the wrap for the management of pain and discomfort. If prescribed, Heat therapy can be used in combination with Pneumatic Compression therapy (see the instructions in Chapter 9.5).

1. To initiate heat therapy, press and hold the **HEAT** key on the display for at least one (1) second. The display will change and now read “Therpy Set 105° F”. Therapy will begin and automatically heat the wrap to the preset temperature.

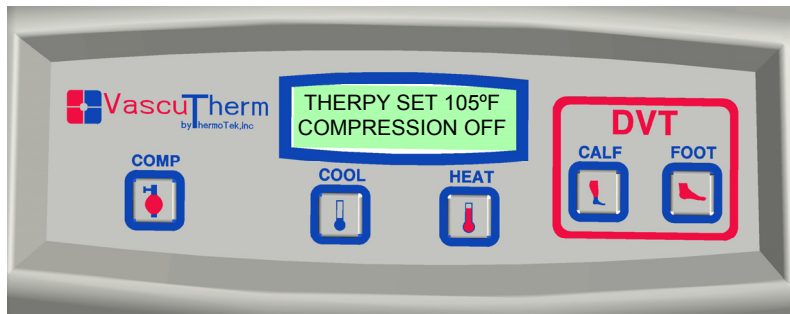

Note: If the desired key is not held for one second or more, the display will read “Hold Key for 1 sec to Start”.

2. At any time during treatment you can tap the **HEAT** key to display the current therapy temperature.

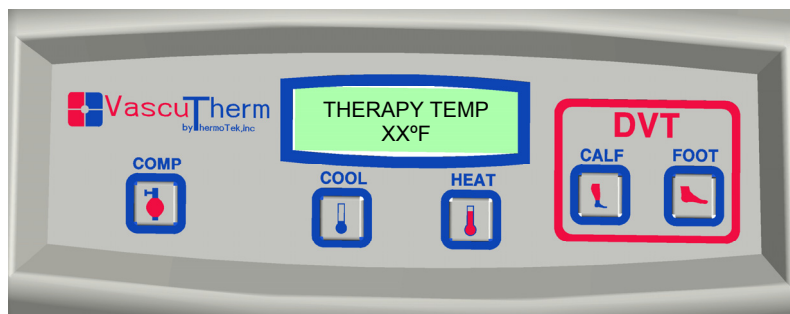

3. To return to the therapy setting screen, simply tap the **HEAT** key again.

Note: After ten seconds, the display will automatically go back to Status screen.

When the prescribed therapy duration is complete:

4. Press and hold the **HEAT** key for at least one second. The therapy will stop and the display will return to the Status screen.

5. If times between treatments are more than one hour, it is recommended to turn the unit OFF. Once the unit is OFF, you may now remove your therapy wraps.

If continuous daily treatments are prescribed, it is best to leave the unit:

- Turned ON,
- Connected to the therapy wrap,
- Controlling to the desired temperature, and
- Compression turned OFF.



Compression should be turned OFF when the therapy wrap is not on the patient. Allowing the wrap to inflate while unattended or to inflate all the way to a “ballooned” state can cause damage to the wrap and will reduce the life of the wrap.



If Compression therapy is being used in combination with Heat therapy, allow the wrap to fully deflate before removing it from the patient.

9.4. Thermal Contrast Therapy:

Thermal Contrast Therapy passes fluid through the wrap in an alternating cycle of Cool-Heat-Cool-Heat for the management of pain, discomfort, and swelling. During Thermal Contrast Therapy, the unit will cool down the circulating fluid to 49°F for twenty (20) minutes and then heat up to 105°F for ten (10) minutes. This cycle is repeated until the prescribed duration of treatment is completed.

1. To initiate thermal contrast therapy, press and hold the **COOL** and **HEAT** keys simultaneously on the display for at least one (1) second. The display will change and now read “CNTRST SET 49°F”. Therapy will begin and automatically alternate the temperature of the fluid passing through the wrap to the preset temperatures.

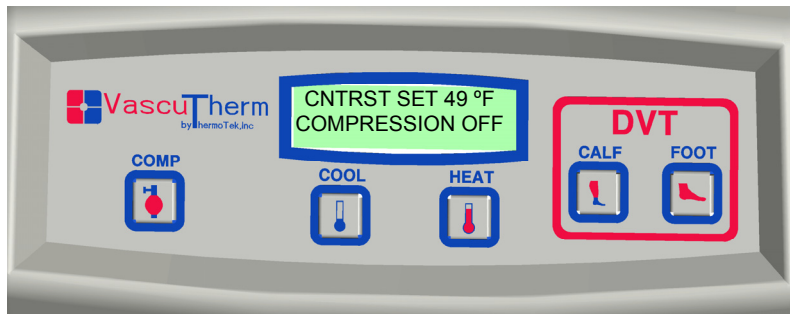

Note: If the desired key is not held for one second or more, the display will read “Hold Key for 1 sec to Start”.

2. At any time during treatment you can tap either the **COOL** or **HEAT** keys to display the current therapy temperature.

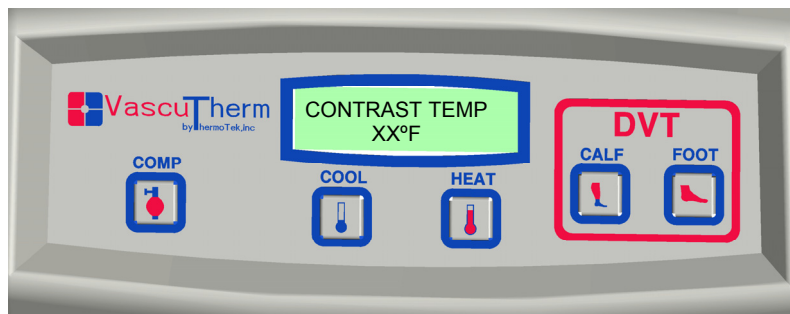

3. To return to the therapy setting screen, simply tap either the **COOL** or **HEAT** keys again.

Note: After ten seconds, the display will automatically go back to the Status screen.

When the prescribed therapy duration is complete:

4. Press and hold the **COOL** and **HEAT** keys simultaneously for at least one second. The therapy will stop and the display will return to the “Status” screen.
5. If times between treatments are more than one hour, it is recommended to turn the unit OFF. Once the unit is OFF, you may now remove your therapy wraps.



Compression should be turned OFF when the therapy wrap is not on the patient. Allowing the wrap to inflate while unattended or to inflate all the way to a “ballooned” state can cause damage to the wrap and will reduce the life of the wrap.



If Compression therapy is being used in combination with Thermal Contrast therapy, allow the wrap to fully deflate before removing it from the patient.

9.5. Pneumatic Compression Therapy for Edema and Lymphedema:

Compression therapy provides compressed air to the therapy wrap and transfers pressure to the treatment site. This added external pressure aids in reducing the pooling of blood and lymphatic fluid in the targeted extremity. The compression treatment provided by the unit uses a preset pressure setting and cycle time.

To help ease discomfort during compression treatments, pneumatic compression therapy can be used in combination with Cool, Heat, or Thermal Contrast therapy. See the instructions in Chapters 9.2, 9.3 and 9.4 for additional details.



Make sure the therapy wrap is applied properly before initiating any compression therapy. Allowing the wrap to inflate while unattended or to inflate all the way to a “ballooned” state can cause damage to the wrap and will reduce the life of the wrap.

1. To change the unit into Pneumatic Compression Therapy mode, tap the **COMP** key. The display will change and now read “Compression Off”.

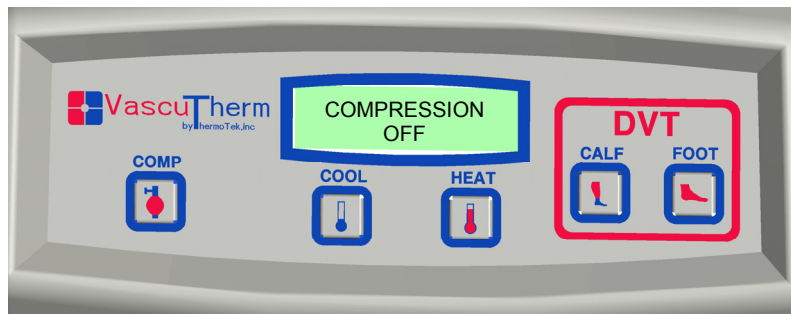

2. To initiate compression therapy, press and hold the **COMP** key for at least one (1) second. The display will change and now read “Compression Alternating”. The wrap will begin to inflate and deflate in a preset time and pressure setting.

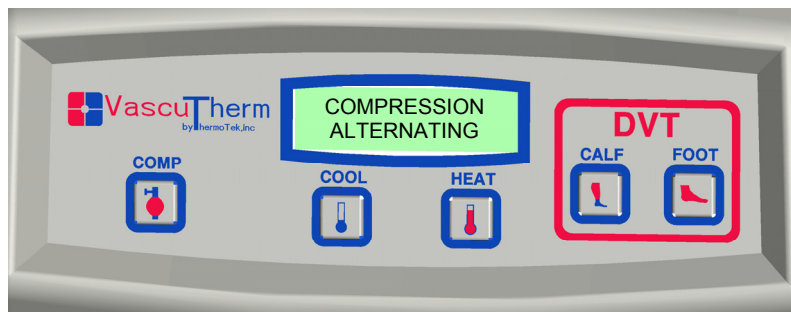

Note: If the compression key is not held for at least one second, the display will read “Hold Key for 1 sec to Start”.

3. If the **COMP** key is tapped again, the display will show the current therapy pressure.

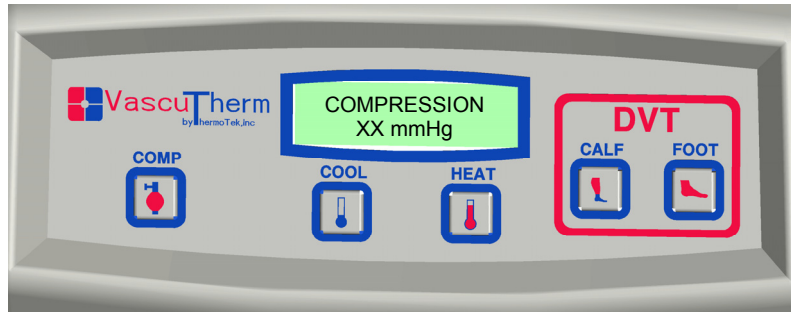

4. To return to the Pneumatic Compression Status screen, simply tap the **COMP** key again.

Note: After ten seconds, the display will automatically go back to the Status screen. If the standard compression and cool therapies are active, the Status screen will read:



When the prescribed therapy duration is complete:

5. If the display is in the Status screen, tap the **COMP** key to bring the Pneumatic Compression Therapy screen.
6. Press and hold the **COMP** key for at least one second. The compression therapy will stop and the bottom line of the Status screen will return to “Compression Off”.
7. If cool or heat therapy was being used in combination with compression therapy, tap either the **COOL** or **HEAT** key to display the temperature therapy setting and status.

8. If no additional therapies are to be used, it is recommended to turn the unit OFF. Once the unit is OFF, you may now remove your therapy wraps.

9.6. DVT Foot Compression Therapy:



Use of foot therapy on the calf or any other wrap treatment area other than the foot may cause harm to the patient.



Make sure the therapy wrap is applied properly before initiating any compression therapy. Allowing the wrap to inflate while unattended or to inflate all the way to a “ballooned” state can cause damage to the wrap and will reduce the life of the wrap.

DVT Foot Compression therapy is used in combination with specially designed therapy wraps to transfer pressure to the foot using compressed air. The preset inflation and deflation cycle of the VascuTherm therapy system simulates natural walking action. This increases blood flow to the heart through the veins of the lower extremities to reduce the risk of clot formation.

1. Tap the **FOOT** key to place the unit into DVT therapy mode. The display will change and now read “DVT Foot Off”.

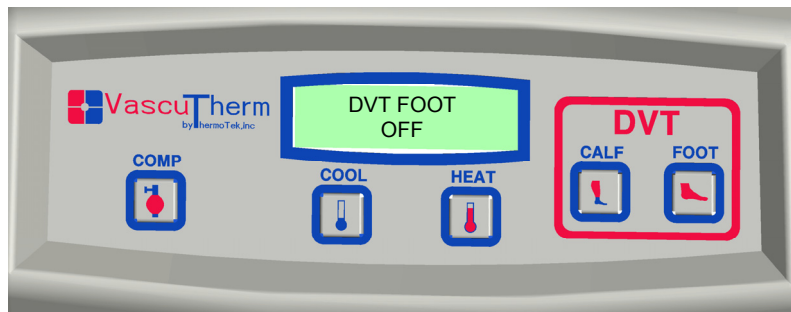

2. Press and hold the **FOOT** key for at least one (1) second. The display will change and now read “DVT Foot Bilateral”. Bilateral compression therapy will automatically alternate compression cycles between the left and right foot wraps.

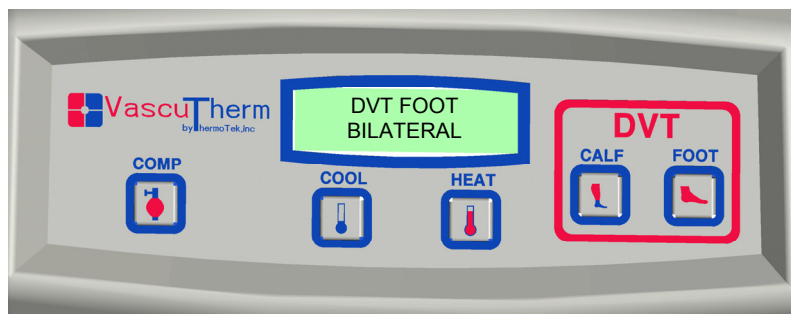

3. If your prescribed therapy is for the left foot or right foot only, press and hold the **FOOT** key until the screen reads either “DVT Foot Left” or “DVT Foot Right”.

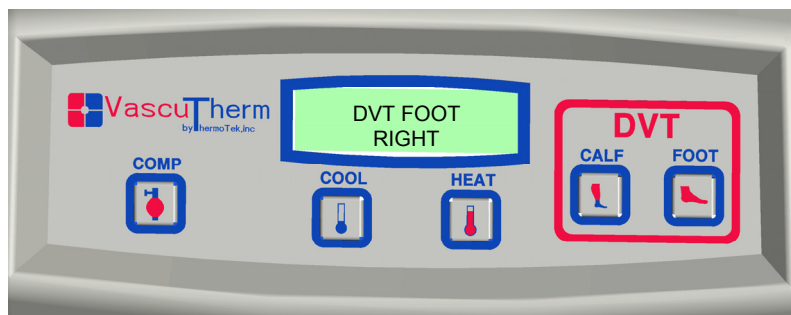
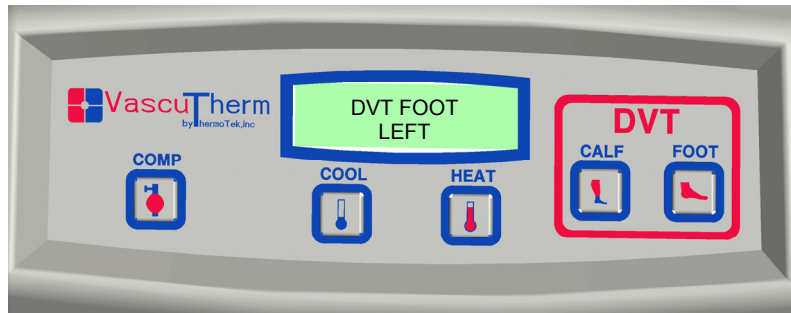

4. At any time during treatment you can tap the **FOOT** key to display the current therapy pressure.

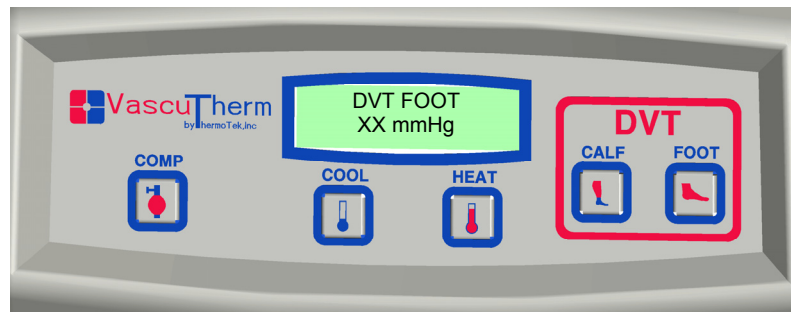

5. To return to the therapy setting screen, simply tap the **FOOT** key again.

Note: After ten seconds, the display will automatically go back to the Status screen. If the DVT Foot Bilateral compression was set with Thermal Therapy in standby, the Status screen will read:

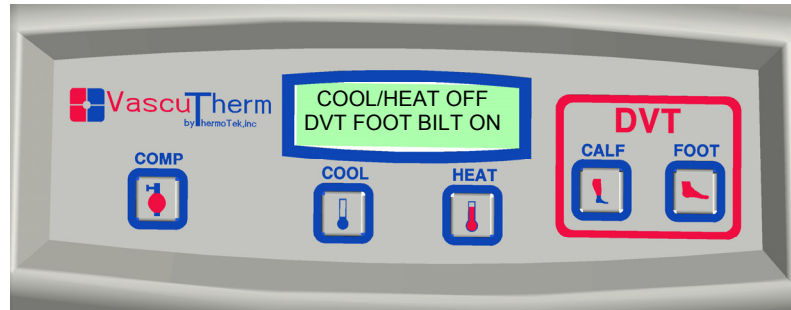

When the prescribed therapy duration is complete:

6. If the display is in Status screen, tap the **FOOT** key to bring the DVT Foot Compression Therapy screen.
7. Press and hold the **FOOT** key until the screen reads “DVT Foot Off”. The therapy will stop after the full compression cycle is complete.
8. If no additional therapies are to be used, it is recommended to turn the unit OFF. Once the unit is OFF, you may now remove your therapy wraps.

Note: Current therapy **must** be terminated before a new or different mode of therapy can be initiated. The display will read as indicated below (depending on current mode of therapy) if this step is not followed. The new mode of therapy will be ready to begin when the current compression cycle is complete.



Compression should be turned OFF when the therapy wrap is not on the patient. Allowing the wrap to inflate while unattended or to inflate all the way to a “ballooned” state can cause damage to the wrap and will reduce the life of the wrap.

9.7. DVT Calf Compression Therapy:



The use of Calf therapy on the Foot is not an effective or approved treatment to reduce the risk of clot formation.



Make sure the therapy wrap is applied properly before initiating any compression therapy. Allowing the wrap to inflate while unattended or to inflate all the way to a “ballooned” state can cause damage to the wrap and will reduce the life of the wrap.

DVT Calf Compression therapy is used in combination with specially designed therapy wraps to transfer pressure to the calf area of the lower leg using compressed air. The preset inflation and deflation cycle of the VascuTherm therapy system simulates natural walking action. This increases blood flow return to the heart through the veins of the lower extremities to reduce the risk of clot formation.

1. Tap the **CALF** key to place the unit into DVT therapy mode. The display will change and now read “DVT Calf Off”.

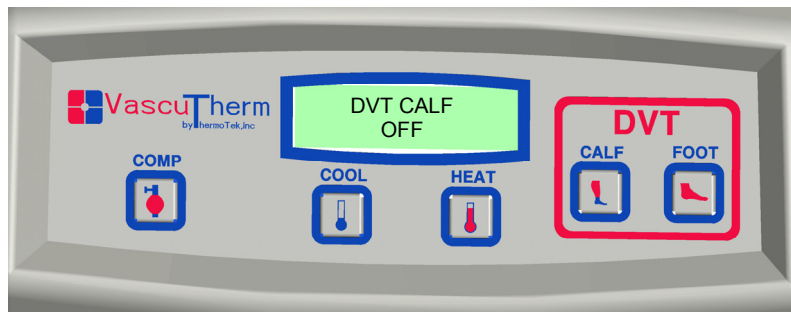

2. Press and hold the **CALF** key for at least one (1) second. The display will change and now read “DVT Calf Bilateral”. Bilateral compression therapy will automatically alternate compression cycles between the left and right calf wraps.

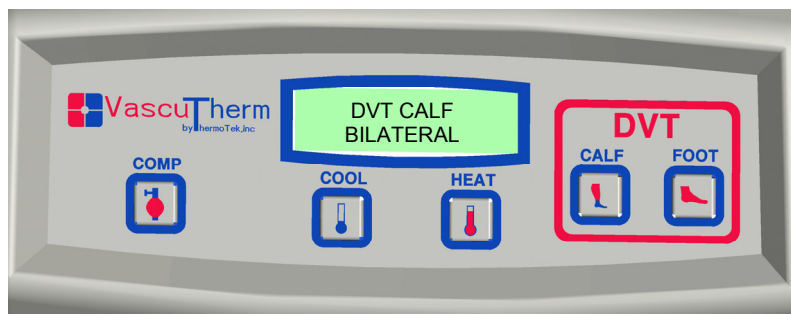

3. If your prescribed therapy is for the left foot or right foot only, press and hold the **CALF** key until the screen reads either “DVT Calf Left” or “DVT Calf Right”.

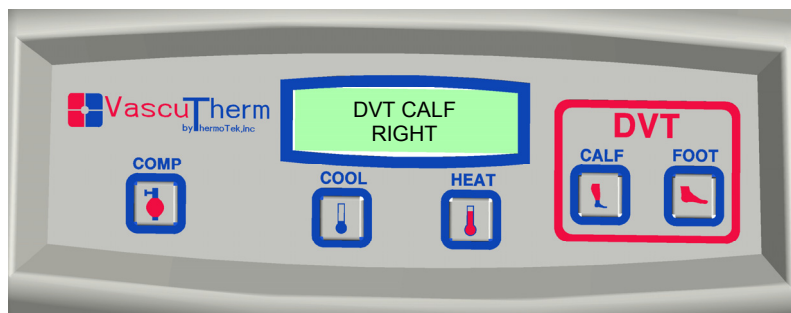
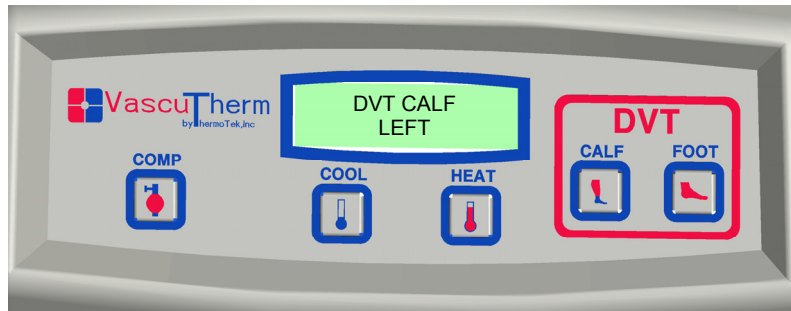

4. At any time during treatment you can tap the **CALF** key to display the current therapy pressure.

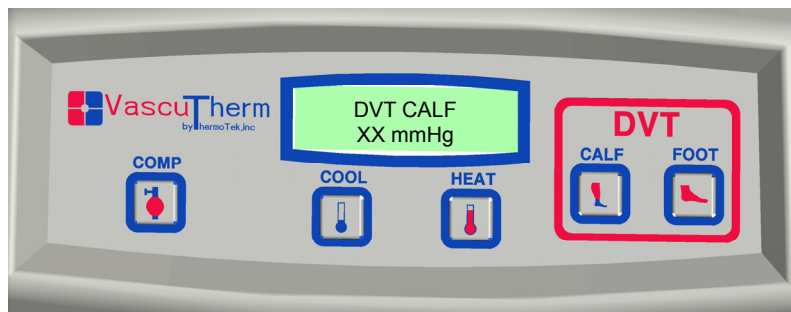

5. To return to the therapy setting screen, simply tap the **CALF** key again.

Note: After ten seconds, the display will automatically go back to the Status screen. If the DVT Calf Left compression was set with Thermal therapy in standby, the Status screen will read:

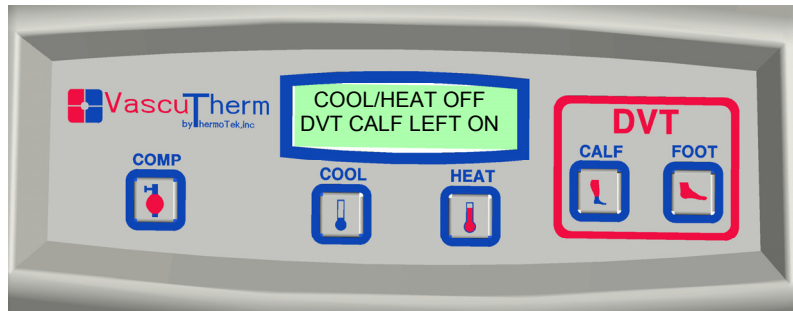

When the prescribed therapy duration is complete:

6. If the display is in Status screen, tap the **CALF** key to bring the DVT Calf Compression Therapy screen.
7. Press and hold the **CALF** key until the screen reads “DVT Calf Off”. The therapy will stop after the full compression cycle is complete.
8. If no additional therapies are to be used, it is recommended to turn the unit OFF. Once the unit is OFF, you may now remove your therapy wraps.

Note: Current therapy **must** be terminated before a new or different mode of therapy can be initiated. The display will read as indicated below (depending on current mode of therapy) if this step is not followed. The new mode of therapy will be ready to begin when the current compression cycle is complete.



Compression should be turned OFF when the therapy wrap is not on the patient. Allowing the wrap to inflate while unattended or to inflate all the way to a “ballooned” state can cause damage to the wrap and will reduce the life of the wrap.

9.8. Pneumatic Compression Therapy and DVT Foot Therapy:



At any time, Pneumatic Compression or DVT Therapy may be turned OFF separately. Turning OFF either compression mode while a wrap is inflated will deflate the respective wrap.



Make sure the therapy wrap is applied properly before initiating any compression therapy. Allowing the wrap to inflate while unattended or to inflate all the way to a “ballooned” state can cause damage to the wrap and will reduce the life of the wrap.

Follow the instructions as follows to set Pneumatic Compression Therapy and DVT Foot Compression Therapy:



Use of foot therapy on the calf or any other wrap treatment area other than the foot may cause harm to the patient.

DVT Foot Compression therapy is used in combination with specially designed therapy wraps to transfer pressure to the foot using compressed air. The preset inflation and deflation cycle of the VascuTherm therapy system simulates natural walking action. This increases blood flow to the heart through the veins of the lower extremities to reduce the risk of clot formation.

1. To change the unit into Pneumatic Compression mode, tap the **COMP** key. The display will change and now read “Compression Off”.

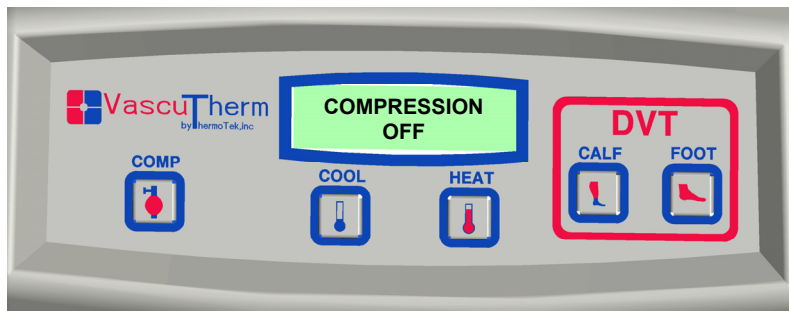

- To initiate Compression therapy, press and hold the **COMP** key for at least one (1) second. The display will change and now read “Compression Alternating”. The wrap will begin to inflate and deflate in a preset time and pressure setting.

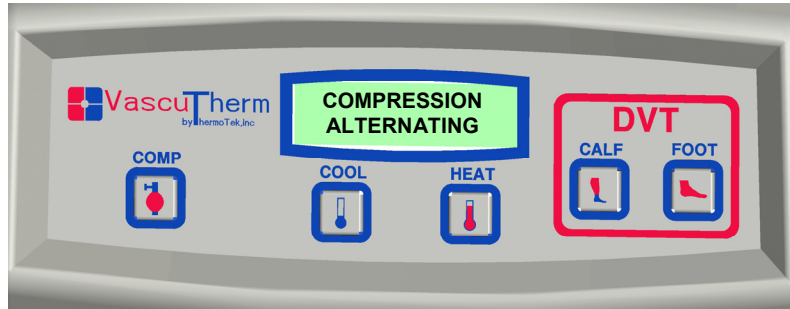

Note: If the Compression key is not held for at least one second, the display will now read “Hold Key for 1 sec to Start”.

- If the **COMP** key is tapped again, the display will show the current therapy pressure.

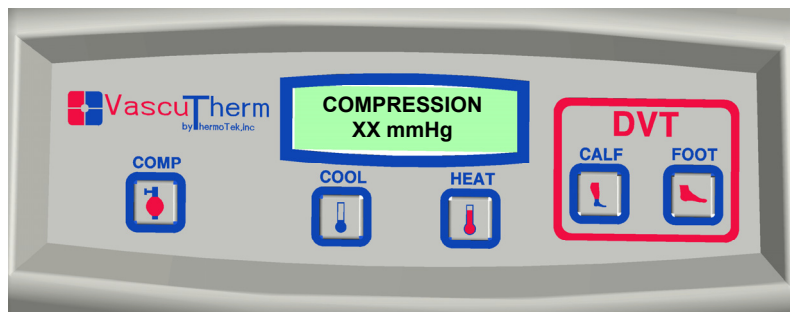

- To return to the Pneumatic Compression Status screen, simply tap the **COMP** key again.

Note: After ten seconds, the display will automatically go back to the Status screen. If the standard compression and cool therapies are active, the Status screen will read:



5. Tap the **FOOT** key to place the unit into DVT therapy mode. The display will change and now read “DVT Foot Off”.

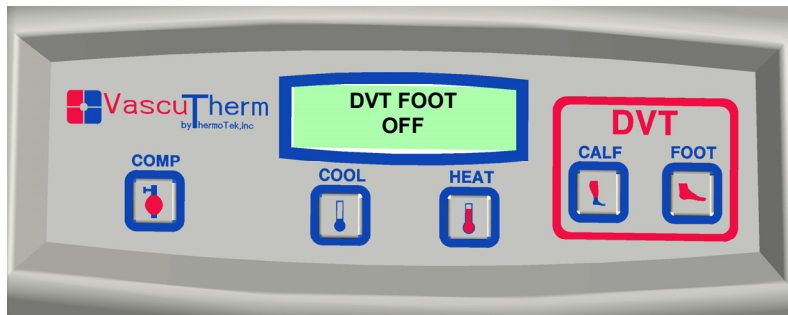

6. Press and hold the **FOOT** key for at least one (1) second. The display will change and now read “DVT Foot Bilateral”. Bilateral compression therapy will automatically alternate compression cycles between the left and right foot wraps.

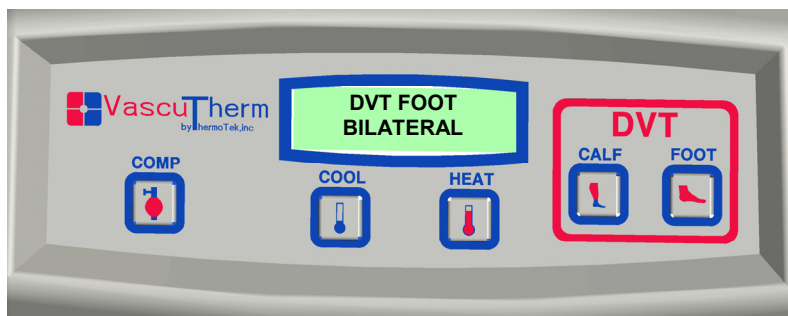

7. If your prescribed therapy is for the left or right foot only, press and hold the **FOOT** key until the screen reads either “DVT Foot Left” or “DVT Foot Right”.



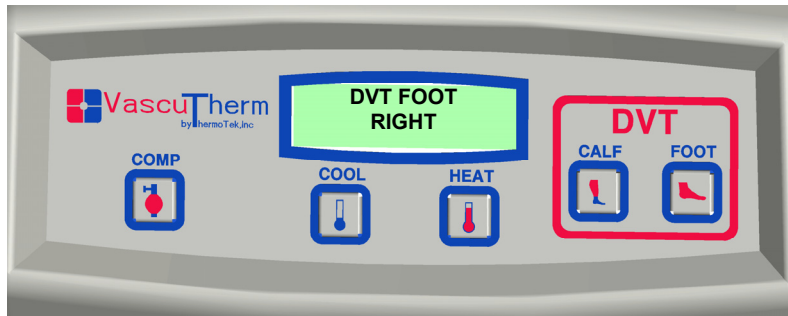

8. At any time during treatment you can tap the **FOOT** key to display the current therapy temperature.

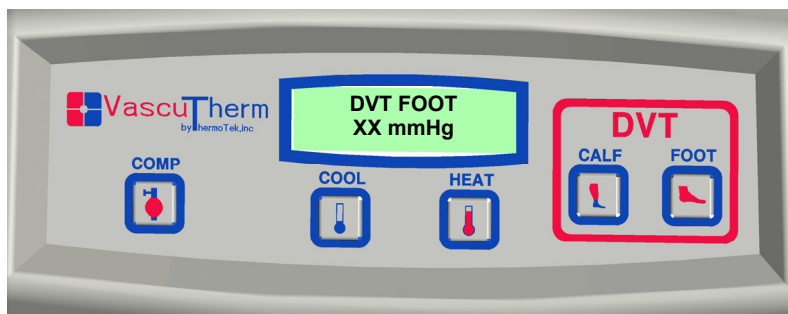

9. To return to the therapy setting screen, simply tap the **FOOT** key again.

Note: After ten seconds, the display will automatically go back to the Status screen. If the DVT Foot Bilateral compression was set with Thermal Therapy in standby and Pneumatic Compression is set, the Status screen will read:

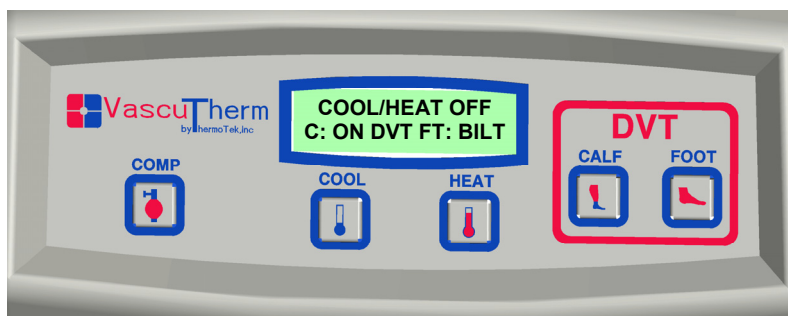

When the prescribed therapy duration is complete:

10. If the display is in the Status screen, tap the **COMP** key to bring the Pneumatic Compression Therapy screen.

11. Press and hold the **COMP** key for at least one second. The compression therapy will stop and the bottom line of the Status screen will return to “Compression Off”.

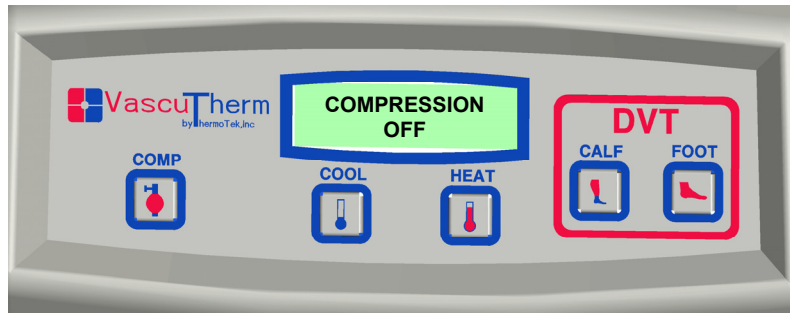

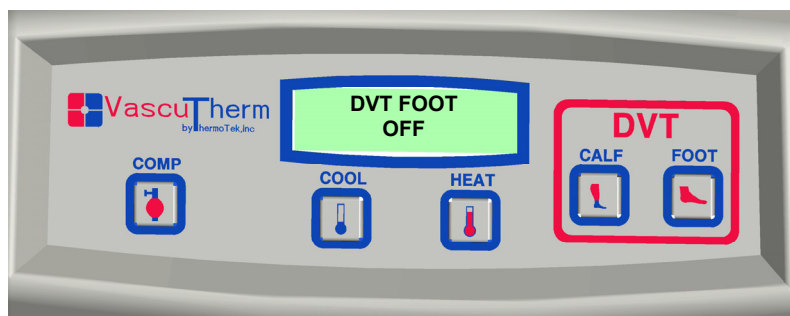

12. If the cool or heat therapy was being used in combination with compression therapy, tap either the **COOL** or **HEAT** key to display the temperature therapy setting and status.
13. If no additional therapies are to be used, it is recommended to turn the unit OFF. Once the unit is OFF, you may now remove your therapy wraps.
14. If the display is in Status screen, tap the **FOOT** key to bring the DVT Foot Compression Therapy screen.
15. Press and hold the **FOOT** key until the screen reads “DVT Foot Off”. The therapy will stop after the full compression cycle is complete.

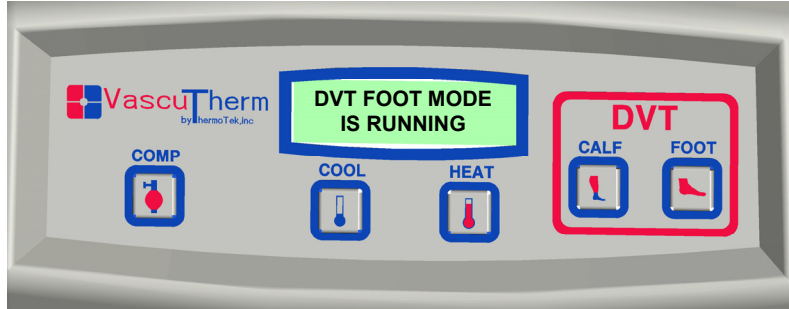

16. If no additional therapies are to be used, it is recommended to turn the unit OFF. Once the unit is OFF, you may now remove your therapy wraps.

Note: Current therapy **must** be terminated before a new or different mode of therapy can be initiated. The display will read as indicated below (depending on current mode of therapy) if this step is not followed. The new mode of therapy will be ready to begin when the current compression cycle is complete.



 Compression should be turned OFF when the therapy wrap is not on the patient. Allowing the wrap to inflate while unattended or to inflate all the way to a “ballooned” state can cause damage to the wrap and will reduce the life of the wrap.

9.9. Pneumatic Compression Therapy and DVT Calf Therapy:



At any time, Pneumatic Compression or DVT Therapy may be turned OFF separately. Turning OFF either compression mode while a wrap is inflated will deflate the respective wrap.



Make sure the therapy wrap is applied properly before initiating any compression therapy. Allowing the wrap to inflate while unattended or to inflate all the way to a “ballooned” state can cause damage to the wrap and will reduce the life of the wrap.

Follow the instructions as follows to set Pneumatic Compression Therapy and DVT Calf Compression Therapy:



Use of calf therapy on the foot is not an effective or approved treatment to reduce the risk of clot formation.

DVT Calf Compression therapy is used in combination with specially designed therapy wraps to transfer pressure to the calf area of the lower leg using compressed air. The preset inflation and deflation cycle of the VascuTherm therapy system simulates natural walking action. This increases blood flow to the heart through the veins of the lower extremities to reduce the risk of clot formation.

1. To change the unit into Pneumatic Compression mode, tap the **COMP** key. The display will change and now read “Compression Off”.

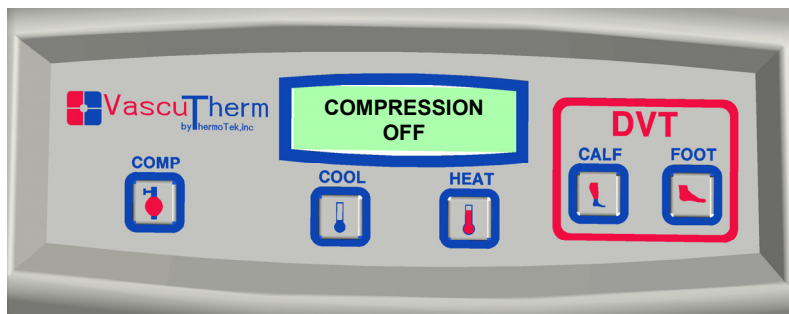

- To initiate Compression therapy, press and hold the **COMP** key for at least one (1) second. The display will change and now read “Compression Alternating”. The wrap will begin to inflate and deflate in a preset time and pressure setting.

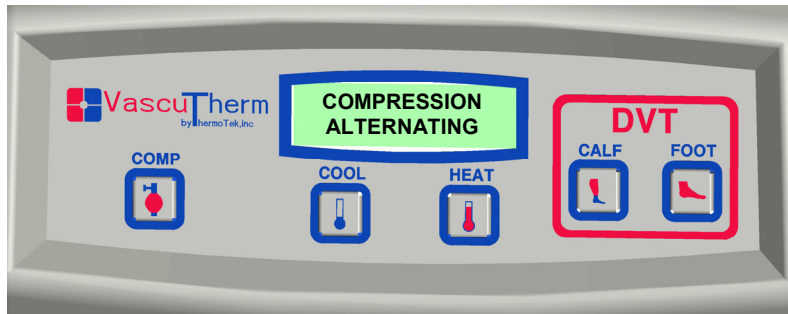

Note: If the Compression key is not held for at least one second, the display will read “Hold Key for 1 sec to Start”.

- If the **COMP** key is tapped again, the display will show the current therapy pressure.

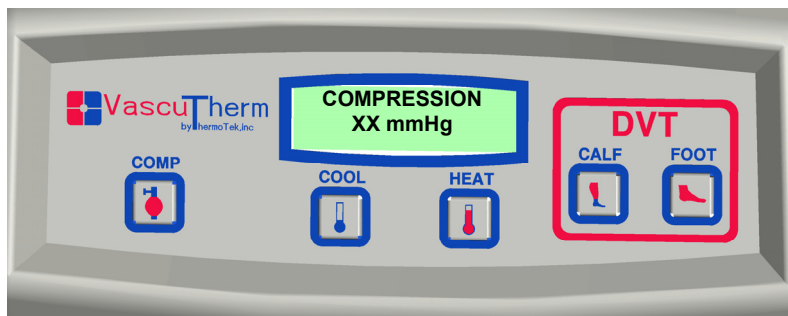

- To return to the Pneumatic Compression Status screen, simply tap the **COMP** key again.

Note: After ten seconds, the display will automatically go back to the Status screen. If the standard compression and cool therapies are active, the Status screen will read:

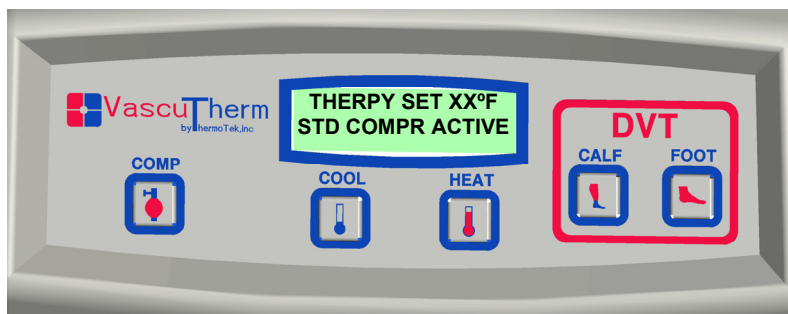

5. Tap the **CALF** key to place the unit into DVT therapy mode. The display will change and now read “DVT Calf Off”.

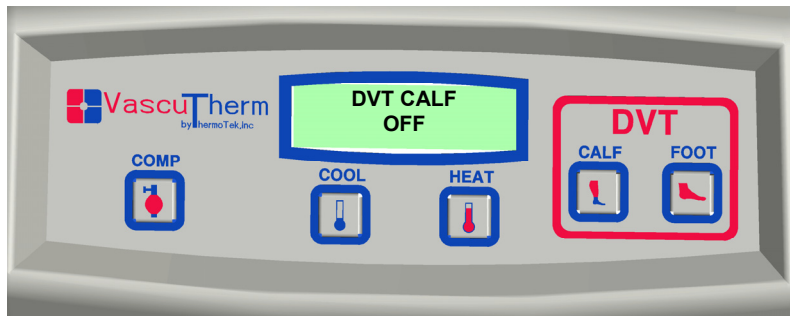

6. Press and hold the **CALF** key for at least one (1) second. The display will change and now read “DVT Calf Bilateral”. Bilateral compression therapy will automatically alternate compression cycles between the left and right calf wraps.

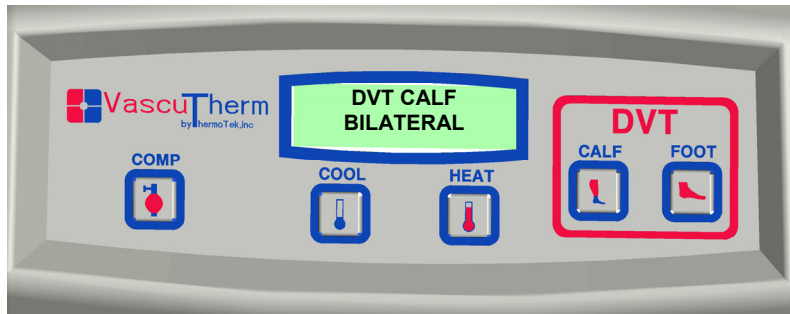

7. If your prescribed therapy is for the left or right calf only, press and hold the **CALF** key until the screen reads either “DVT Calf Left” or “DVT Calf Right”.

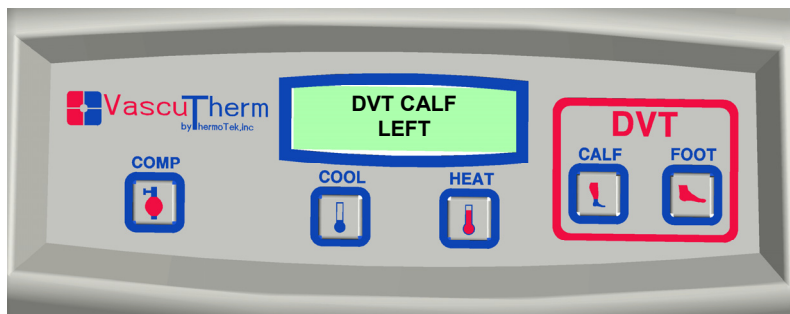

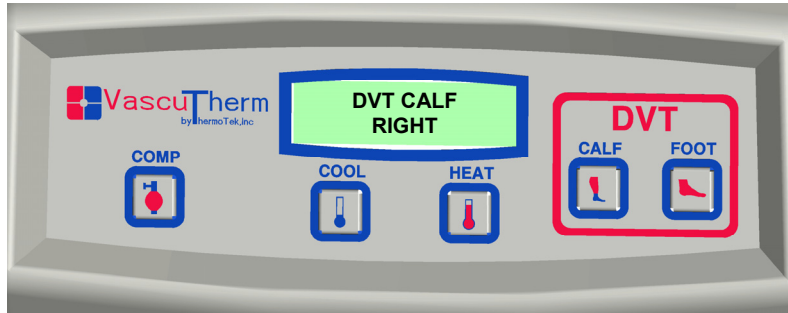

8. At any time during treatment you can tap the **CALF** key to display the current therapy temperature.

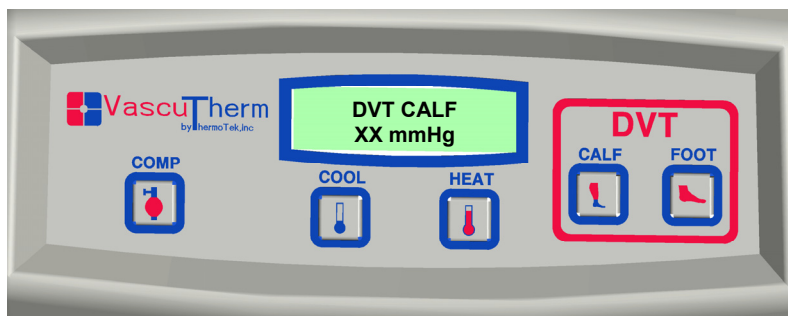

9. To return to the therapy setting screen, simply tap the **CALF** key again.

Note: After ten seconds, the display will automatically go back to the Status screen. If the DVT Calf Left compression was set with Thermal Therapy in standby and Pneumatic Compression is set, the Status screen will read:

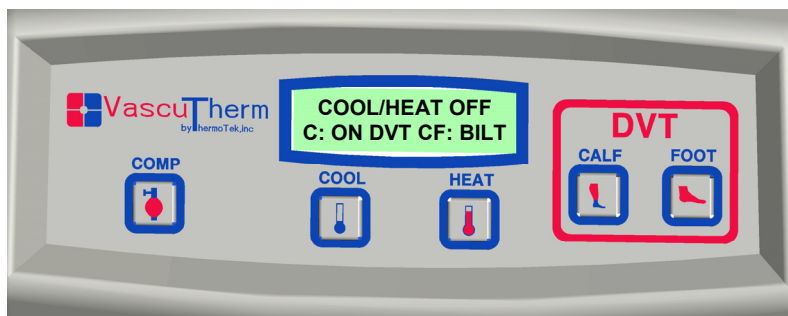

When the prescribed therapy duration is complete:

10. If the display is in the Status screen, tap the **COMP** key to bring the Pneumatic Compression Therapy screen.

11. Press and hold the **COMP** key for at least one second. The compression therapy will stop and the bottom line of the Status screen will return to “Compression Off”.

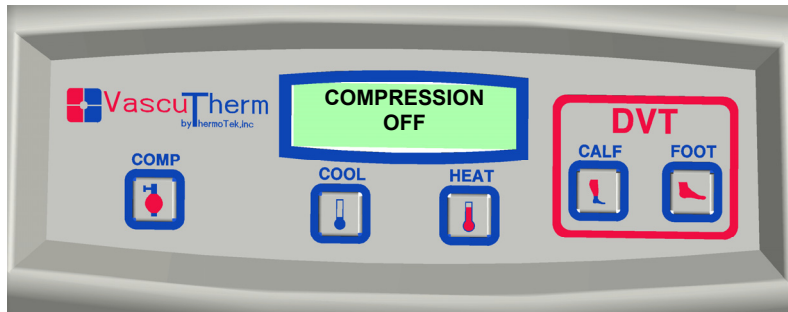

12. If the cool or heat therapy was being used in combination with compression therapy, tap either the **COOL** or **HEAT** key to display the temperature therapy setting and status.
13. If no additional therapies are to be used, it is recommended to turn the unit OFF. Once the unit is OFF, you may now remove your therapy wraps.
14. If the display is in Status screen, tap the **CALF** key to bring the DVT Calf Compression Therapy screen.
15. Press and hold the **CALF** key until the screen reads “DVT Calf Off”. The therapy will stop after the full compression cycle is complete.

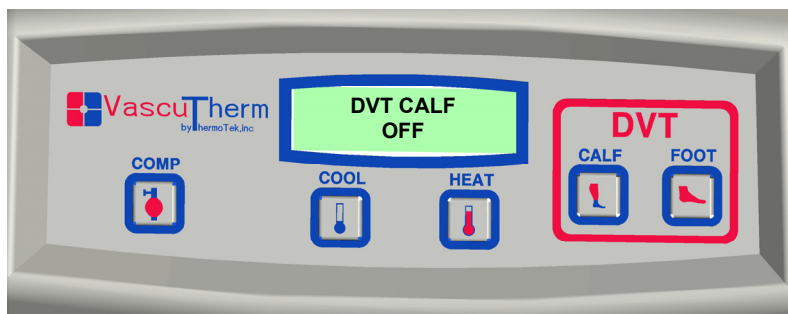

16. If no additional therapies are to be used, it is recommended to turn the unit OFF. Once the unit is OFF, you may now remove your therapy wraps.

Note: Current therapy **must** be terminated before a new or different mode of therapy can be initiated. The display will read as indicated below (depending on current mode of therapy) if this step is not followed. The new mode of therapy will be ready to begin when the current compression cycle is complete.



 Compression should be turned OFF when the therapy wrap is not on the patient. Allowing the wrap to inflate while unattended or to inflate all the way to a “ballooned” state can cause damage to the wrap and will reduce the life of the wrap.

10. Display Messages and Alarm Indicators

10.1. Normal Operation

The following list contains display messages that you may encounter during normal therapy operation:

- **VascuTherm Rev: Vascu_xx_yy:** Boot-up screen displayed temporarily.
- Default display screen is Status screen with the top line showing Thermal Therapy operation mode and the bottom line showing Compression Therapy operation mode.

Top Display Line Options:

- **Cool/Heat Off:** Thermal subsystem in idle. System ready to begin prescribed therapy.
- **Therpy Set XX °F:** Preset cool mode therapy temperature is active. (XX in 43-50 °F range).
- **Therpy Setting 105 °F:** Preset heat mode therapy temperature is active.
- **CNTRST SET XX °F:** Preset cycling between cool and heat therapy temperatures (XX = 49 or 105).

Bottom Display Line Options:

- **Compression Off:** Pneumatic subsystem in idle. System ready to begin prescribed therapy.
- **STD Compr On:** Compression Therapy for Edema and Lymphedema (standard) is active.
- **Timer: H:MM:** Preset Therapy Timer.
- **DVT Foot Bilt On:** DVT Foot Bilateral Therapy is active.
- **DVT Foot Left On:** DVT Foot Left Therapy is active.
- **DVT Foot Right On:** DVT Foot Right Therapy is active.
- **DVT Calf Bilt On:** DVT Calf Bilateral Therapy is active.

- **DVT Calf Left On:** DVT Calf Left Therapy is active.
 - **DVT Calf Right On:** DVT Calf Right Therapy is active.
 - **C: ON DVT FT: BILT:** DVT Foot Bilateral Therapy is active. Compression Therapy for Edema and Lymphedema is active.
 - **C: ON DVT FT: LEFT:** DVT Left Foot Therapy is active. Compression Therapy for Edema and Lymphedema is active.
 - **C: ON DVT FT: RGHT:** DVT Right Foot Therapy is active. Compression Therapy for Edema and Lymphedema is active.
 - **C: ON DVT CF: BILT:** DVT Calf Bilateral Therapy is active. Compression Therapy for Edema and Lymphedema is active.
 - **C: ON DVT CF: LEFT:** DVT Left Calf Therapy is active. Compression Therapy for Edema and Lymphedema is active.
 - **C: ON DVT CF: RGHT:** DVT Right Calf Therapy is active. Compression Therapy for Edema and Lymphedema is active.
- **Hold Key for 1 sec To Start:** Desired key was not held long enough to start the selected therapy setting.
 - **Therapy Temp XX° F:** The current therapy temperature.
 - **Contrast Temp XX °F:** The current contrast therapy temperature.
 - **Compression Off:** Pneumatic compression is not currently operating.
 - **Compression Alternating:** Pneumatic compression therapy is currently active and cycling.
 - **Compression XX mmHg:** The current compression level in the wrap.
 - **DVT Foot Off:** DVT Foot therapy mode is selected but not currently engaged.
 - **DVT Foot Bilateral:** DVT Foot therapy mode is active and currently providing alternating compression treatment between the left and right feet by the preset cycle.

- **DVT Foot Left:** DVT Foot therapy mode is selected and currently providing compression cycles to the left foot only.
- **DVT Foot Right:** DVT Foot therapy mode is active and currently providing compression cycles to the right foot only.
- **DVT Foot XX mmHg:** The current compression level in the foot wrap.
- **DVT Calf Off:** DVT Calf therapy mode is selected but not currently engaged.
- **DVT Calf Bilateral:** DVT Calf therapy mode is active and currently providing alternating compression treatment between the left and right lower-legs by the preset cycle.
- **DVT Calf Left:** DVT Calf therapy mode is active and currently providing compression cycles to the left lower-leg only.
- **DVT Calf Right:** DVT Calf therapy mode is active and currently providing compression cycles to the right lower-leg only.
- **DVT Calf XX mmHg:** The current compression level in the calf wrap.

10.2. Warnings, Alarms, and System Errors

The VascuTherm Therapy System has many internal software safeguards to help protect the patient and the unit from unsafe operation. In this section you will find a list of possible system warnings and alarms that may occur if a potentially unsafe situation arises while using the VascuTherm unit.

Warnings indicate that an unsafe condition could or is about to occur. Warning notifications combine the use of a flashing description on the upper line of the display and a fast beeping noise.

Alarms indicate that an unsafe condition is currently present and halts all current therapies to protect the patient. The alarm state must be corrected before any therapy can be restarted. Alarm notification combines the use of “ALARM ACTIVE” text on the upper line and an alarm description on the lower line of the display. An audible notification is also initiated by a slow beeping noise. Press any button to clear the active alarm. If the alarm state is still present, the alarm message will reappear and prevent the start of any therapy.

System Errors indicate that an internal software or hardware error has occurred and that an unsafe condition is currently present and all current therapies are halted to protect the patient. An example of this is when there is a problem reading from one of the internal sensors. System errors typically require service to the unit to identify and correct the problem. If you encounter a system error, please write down the 3-digit number indicated on the display and contact the clinic or hospital that prescribed the unit or the Durable Medical Equipment (DME) provider. If assistance is not available or ineffective, please contact ThermoTek technical assistance toll-free at 1-877-242-3232 during the hours of 8am-5pm Central Time. If technical assistance is needed after these hours, you may contact the 24-hour line at (214) 502-8800.

Below is a list of common user-related warnings and alarms that may occur during therapy operation of the unit.

!!WARNING ACTIVE!! BLOCKED AIR FLOW: When using any of the pneumatic compression therapies available, the software monitors the rate of air pressure change. If the rate air pressure change is faster than a preset value in a preset time this warning activates.

!!WARNING ACTIVE!! CHECK WRAP: When using any of the pneumatic compression therapies available on the unit, the software monitors the amount of time taken to properly inflate the wrap. If a preset time expires before proper inflation was reached this warning activates.

!!WARNING ACTIVE!! CHECK FLOW/FLUID: When using either the COOL or HEAT temperature therapies available on the unit, the software monitors the units ability to change the coolant temperature. If the software suspects that the unit was not able to properly alter the coolant temperature due to a low coolant level or low coolant flow rate this warning activates.

!!WARNING ACTIVE!! BLOCKED AIR FLOW: When using any of the pneumatic compression therapies available, the software monitors the rate of air pressure change. If the rate air pressure change is faster than a preset value in a preset time a warning activates first. If the warning continues and the rate of pressure change is not in a normal range, this alarm activates.

!!ALARM ACTIVE!! CHECK WRAP: When using any of the pneumatic compression therapies available on the unit, the software monitors the amount of time taken to properly inflate the wrap. If a preset time expires before proper inflation was reached, a warning activates first. If the warning continues and the wrap is still unable to properly inflate, this alarm activates.

!!ALARM ACTIVE!! HIGH H-SINK TEMP: Anytime the unit is turned ON, the software constantly monitors the temperature of the heat sink fins visible on either side of the unit. If the software determines that the heat sink fin temperature is hotter than a safe level this alarm activates.

!!ALARMS ACTIVE!! HIGH TEMP ALARM: Anytime the unit is turned ON, the software constantly monitors the temperature of the internal coolant manifold. If the software determines that the temperature of the manifold is hotter than a safe level, this alarm activates.

!!ALARMS ACTIVE!! KINKED WRAP - H: When using any of the pneumatic compression therapies available on the unit, an independent backup pressure switch constantly monitors the system air pressure value. This alarm activates if the software controlled pneumatic solenoids fail to properly activate during an emergency pressure vent and the backup pressure safety switch activates. The software monitors and detects that the pressure safety switch has engaged and this alarm activates.

!!ALARMS ACTIVE!! KINKED WRAP – S: When using any of the pneumatic compression therapies available on the unit, the software monitors the current air pressure value by way of an internal pressure sensor in the event that unsafe high pressure is detected by the pressure sensor, the software executes an emergency pressure vent and this alarm activates to notify the patient of the therapy termination.





!!ALARM ACTIVE!! CHECK FLOW/FLUID: When using either the COOL or HEAT temperature therapies available on the unit, the software monitors the units ability to change the coolant temperature. If the software suspects that the unit was not able to properly alter the coolant temperature due to a low coolant level or low coolant flow rate a warning activates first. If the warning continues and the unit is still unable to properly alter the coolant temperature due to a low coolant level or low coolant flow rate this alarm activates.

!!ALARM ACTIVE!! LOW H-SINK TEMP: Anytime the unit is turned ON, the software constantly monitors the temperature of the heat sink fins visible on either side of the unit. If the software determines that the heat sink fin temperature is colder than a safe level this alarm activates.

!!ALARM ACTIVE!! LOW TEMP ALARM: Anytime the unit is turned ON, the software constantly monitors the temperature of the internal coolant manifold. If the software determines that the temperature of the manifold is colder than a safe level, this alarm activates.

SYSTEM ERROR XXX: This alarm indicates that an internal software or hardware error has occurred. The unit potentially requires service by an authorized technician. If you encounter a system alarm, please write down the 3-digit number indicated on the display and contact the clinic or hospital that prescribed the unit or the Durable Medical Equipment (DME) provider. If assistance is not available or ineffective, please contact ThermoTek technical assistance toll-free at 1-877-242-3232 during the hours of 8am-5pm Central Time. If technical assistance is needed after these hours, you may contact the 24-hour line at 214-502-8800.

11. Things You Can Do To Keep Your VascuTherm System Performing

-  Do not use abrasive or solvent-based cleaners on the unit.
-  There are no user serviceable internal parts. The system warranty is voided if the tamper seals are breached or removed.
-  Keep water away from vents, power ON/OFF switch and the power cord connection of the unit.
-  To avoid possible electric shock, do not remove the cover of the unit.
-  Do not immerse the unit in water or any liquid.

- **Check the fluid level weekly.**

If the coolant mixture ever becomes discolored or offensive to smell, contact the clinic or hospital that prescribed the unit or the Durable Medical Equipment (DME) provider for assistance. If microbial growth is present and the unit should not be used.

If assistance is not available or is ineffective, please contact ThermoTek technical assistance toll-free at 1-877-242-3232 during the hours of 8am-5pm Central Time. If technical assistance is needed after these hours, you may contact the 24-hour line at 214-502-8800.

- **Wipe the exterior of the unit with a damp cloth.**

Do not use abrasive or solvent-based cleaners on the unit.

- **Clean off the therapy wrap if used for longer than 2-weeks or when noticeably dirty.**

Clean the exposed surfaces of the wrap with either a mild antibacterial soap and water solution or an isopropyl alcohol and water solution.

Do not use bleach on the wraps. This will weaken the plastic material and can cause either an air or coolant leak.

- **Cleaning the filter:**

1. The filter is attached to the unit with Velcro strips. Carefully remove (separate) the filter from the Velcro strips installed to the unit.
2. Use warm, soapy water to clean the filter.
3. Allow the filter to air dry completely before re-installing to the unit.

- **Re-installing the filter:**



The air filter must be completely dry before installing on the unit. Using a wet air filter has a strong risk of causing an internal electrical short and is hazardous to both the user and the unit.

1. Turn the unit OFF and disconnect the power cord.
2. Starting at the rear of either side of the unit, begin attaching one end of the air filter towards and around the front of the unit using the Velcro strips.
3. Continue attaching the air filter around to the opposite side of the unit.
4. The filter should be taught without bulge across the top and bottom of the filter to prevent bypassing of air.

12. Draining the Fluid from the Unit

Periodically between uses or if the unit is going to be stored for a long period of time, the system should be drained of fluid.

1. Turn the unit OFF and unplug from electrical source.
2. Disconnect all of the hoses from the unit.
 - a. Firmly press the metal tabs of the fitting attached to the hose.
 - b. Gently pull back the hose from the unit to release.
 - c. If the hoses are attached to the DVT air fittings, simply press in on the fitting while twisting counter-clockwise to release it from the unit.
3. Remove the reservoir cap from the unit by twisting the cap counter-clockwise.
4. Lift the unit on both ends and tip backward to empty the fluid from the reservoir into a bucket or sink.

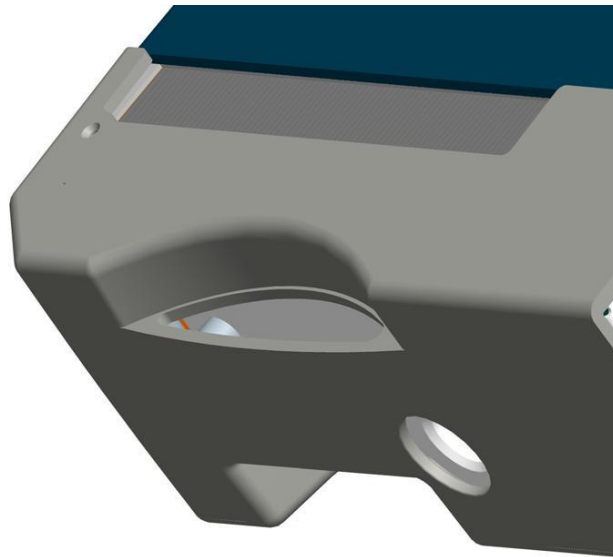

5. Continue to tip the unit until the reservoir is completely empty of all fluid.

13. Storage and Re-Packing the Unit

When therapy is complete and it is time to return or store the VascuTherm therapy system you can use the transport box.

1. Turn the unit OFF and unplug from the electrical source.
2. Remove all therapy wraps.
3. Disconnect all fittings from the rear panel of the unit.
4. If you have a hose assembly umbilical with your unit, disconnect the therapy wrap from the umbilical assembly.
5. Follow the “Draining the Fluid from the Unit” instructions in Chapter 12.
6. Do not screw the unit’s reservoir cap on, but rather leave it off to allow the unit to dry completely. This helps avoid the risk of microbial growth in the unit during storage or long transport.
7. Collect the following items together:
 - VascuTherm Unit
 - Reservoir Cap
 - Hoses
 - Power Cord
 - User Manual
 - Coolant Mixing Bottle
 - Hand-carry Box with Package Inserts
8. Store the above items in the original packaging box or in the travel case you received.
9. All therapy wraps are for single patient use only. If the patient is going to restart therapy later with a non-sterile wrap, retain the wrap with the unit. If the patient is going to restart therapy with a sterile wrap or is discontinuing therapy, the wrap can now be discarded.
10. Store indoors in an ambient environment between 40 °F and 105 °F.

Failure to properly store the unit, wraps and umbilical may result in the following:



Damage to the unit, hoses and/or wraps.



Catastrophic system damage if the unit is not properly drained.



Microbial growth inside the unit if not properly drained.

14. Troubleshooting Guide

Refer to Chapter 7 “Environmental Conditions You Should Be Aware of Before Operating Your VascuTherm Device” for a list of acceptable environmental conditions for safe operation.

Neither the unit nor the wraps are intended for field repair. Do not attempt to service the unit in any way other than using the instructions listed in this guide.

If the unit is displaying an alarm, warning, or system error not listed in the above Troubleshooting Guide, contact Customer Support. See the Customer Support contact information below.

If your issue cannot be resolved with the following scenarios, first contact the clinic or hospital that prescribed the unit or the Durable Medical Equipment (DME) provider. If assistance is not available or ineffective, please contact ThermoTek technical assistance toll-free at 1-877-242-3232 during the hours of 8am-5pm Central Time. If technical assistance is needed after these hours, you may contact the 24-hour line at 214-502-8800.

Problem	Cause	Suggested Actions
Nothing happens when I turn the unit to the ON position.	No AC Power to the unit.	Make sure the unit is plugged into the appropriate electrical outlet. Make sure the power cord is also plugged into the therapy unit.
	Internal fault within the therapy unit.	Turn the power switch off, wait, and turn it back on. Contact ThermoTek customer service if problem persists.

Problem	Cause	Suggested Actions
My unit gives me a CHECK FLOW/FLUID alarm. (cont'd on next page)	There is a kink in the wrap.	Turn the power switch to the OFF position. Check for any folds or kinks on the wrap. Readjust wrap to alleviate the blockage. Turn ON the unit and restart therapy.

Problem	Cause	Suggested Actions
<p>My unit gives me a CHECK FLOW/FLUID alarm. (cont'd on next page)</p>	<p>Coolant ports not connected properly.</p>	<p>Turn the power switch to the OFF position.</p> <p>Check if coolant ports are connected to the wrap.</p> <p>To make sure proper connection, disconnect and reconnect the ports at the wrap. You should hear a “click” sound when the connectors are mated correctly.</p> <p>Turn ON the unit and restart therapy.</p>
	<p>Reservoir is low on coolant.</p>	<p>Make sure the therapy mode is set to COOL mode and the display is showing “THERPY SET 49° F”</p> <p>Open the reservoir cap. Check the fluid level and if necessary add fluid to the bottom of the neck.</p> <p>Run the system with the cap open for one minute.</p> <p>Close cap tightly.</p>
	<p>Air bubbles trapped within the unit.</p>	<p>Make sure the therapy mode is set to COOL mode and the display is showing “THERPY SET 49° F”</p> <p>Check the clear tubing on the wrap for air bubbles.</p> <p>If air bubbles are present, open the reservoir cap.</p> <p>Run the system with the cap open for 5 minutes.</p> <p>Tapping the clear tubing on the wrap, with a finger, will also aid in the release of the air bubbles.</p> <p>Close cap tightly.</p>

Problem	Cause	Suggested Actions
My unit gives me a CHECK FLOW/FLUID alarm.	Airports not connected properly.	<p>Turn the power switch to the OFF position.</p> <p>Check if airports are connected to the wrap.</p> <p>To make sure proper connection, disconnect and reconnect the ports at the wrap. You should hear a “click” sound when the connectors are mated correctly.</p> <p>Turn ON the unit and restart therapy.</p>

Problem	Cause	Suggested Actions
My unit gives me a CHECK WRAP alarm. Therapy Wrap is not compressing.	Wrap is loose on the patient.	<p>If the wrap is “ballooned” on the patient, it has been applied loosely.</p> <p>Remove wrap and reapply tightly to fit the patient.</p>
	System software detected a kink in the wrap.	Make sure the patient is not asserting excessive force on the wrap. This will cause the wrap pressure to spike and trip this alarm.

Problem	Cause	Suggested Actions
My unit gives me a KINKED WRAP - S alarm.	Internal fault within the therapy unit.	Turn the power switch off, wait, and turn it back on. Contact ThermoTek customer service if problem persists.
	System hardware detected a kink in the wrap.	Make sure the patient is not asserting excessive force on the wrap. This will cause the wrap pressure to spike and trip this alarm.

Problem	Cause	Suggested Actions
My unit gives me a KINKED WRAP - H alarm.	Internal fault within the therapy unit.	Turn the power switch off, wait, and turn it back on. Contact ThermoTek customer service if problem persists.
	The unit was powered on after being in a hot environment [e.g. trunk of a car]	Make sure the unit is used indoors with an ambient temperature < 80° F. If the alarm activates after power up, let it be in the alarm state until it clears. During this alarm the unit will run with the fans in full power to cool the unit.

Problem	Cause	Suggested Actions
My unit gives me a HIGH H- SINK alarm.	Dirty air filter.	Check the filter. If it is dirty, clean or replace with new filter. Refer to Chapter 11 for details.
	Unit operated in a place with restricted airflow.	Make sure the unit is operated in a location with adequate airflow from all sides. Make sure there is at least 6” of clearance around the unit.
	Unit is operated in a hot ambient environment	Make sure the unit is operated indoors in an ambient < 80° F
	Internal fault within the therapy unit.	Turn the power switch off, wait, and turn it back on. Contact ThermoTek customer service if problem persists.
	The unit was powered on after being in a cold environment [e.g. trunk of a car]	Make sure the unit is used indoors with an ambient temperature > 60° F. If the alarm activates after power up, let it be in the alarm state until it clears. During this alarm the unit will run with the fans in full power to warm the unit.

Problem	Cause	Suggested Actions
My unit gives me a LOW H- SINK alarm.	Unit is operated in a cold ambient environment.	Make sure the unit is operated indoors in an ambient > 60° F.
	Internal fault within the therapy unit.	Turn the power switch off, wait, and turn it back on. Contact ThermoTek customer service if problem persists.
	The unit was powered on after being in a hot environment [e.g. trunk of a car]. The hot environment raised the coolant temperature within the unit to alarm limits of > 113° F.	Make sure the unit is used indoors with an ambient temperature < 80° F. If the alarm activates after power up, let it be in the alarm state until it clears. During this alarm the unit will run with the fans in full power to cool the unit. Once the alarm clears start therapy.

Problem	Cause	Suggested Actions
My unit gives me a HIGH TEMP alarm.	The unit was filled with hot coolant.	Make sure the unit is filled with room temperature fluid.
	Unit is operated in a hot ambient environment.	Make sure the unit is operated indoors in an ambient < 80° F.
	Internal fault within the therapy unit.	Turn the power switch off, wait, and turn it back on. Contact ThermoTek customer service if problem persists.
	The unit was powered on after being in a cold environment [e.g. trunk of a car].	Make sure the unit is used indoors with an ambient temperature > 60° F. If the alarm activates after power up, let it be in the alarm state until it clears. During this alarm the unit will run with the fans in full power to warm the unit.
	The wrap is kinked.	Remove the therapy wrap and allow the unit to run without compression. Re-apply the therapy wrap and continue.

Problem	Cause	Suggested Actions
My unit gives me a LOW TEMP alarm.	The unit was filled with cold coolant.	Make sure the unit is filled with room temperature fluid.
	Unit is operated in a cold ambient environment.	Make sure the unit is operated indoors in an ambient > 60° F.
	Internal fault within the therapy unit.	Turn the power switch off, wait, and turn it back on. Contact ThermoTek customer service if problem persists.
	Internal fault within the therapy unit.	Turn the power switch off, wait, and turn it back on. Contact ThermoTek customer service if problem persists

Problem	Cause	Suggested Actions
My unit gives me a SYSTEM ERROR XXX alarm.	Reservoir cap is not screwed tightly.	Make sure the unit is unplugged from the AC outlet. Check the reservoir cap and secure it tightly. Connect to AC power and restart unit.

Problem	Cause	Suggested Actions
The unit is leaking. (cont'd on next page)	The coolant ports are not connected / seated properly.	Make sure the unit is unplugged from the AC outlet. Check the coolant connections; disconnect and reconnect the ports to make sure they are seated properly.
	Physical damage to the unit.	Inspect the unit for physical damage. . If the unit shows any cracks or dents and is leaking, the unit should not be used. Contact ThermoTek Customer Support.

Problem	Cause	Suggested Actions
The unit is leaking.	Condensation on the wrap.	<p>If the patient is utilizing cool therapy, remove the wrap and wipe it down with a clean, dry cloth.</p> <p>Moisture buildup could be condensation rather than a leak.</p> <p>If water returns immediately, discard the wrap and Contact Customer Support.</p>

Problem	Cause	Suggested Actions
The wrap is leaking.	The coolant ports are not connected / seated properly.	Disconnect and reseal all fluid connections on the umbilical/hose assembly.
	Physical damage to the unit.	<p>If the wrap is leaking, turn the unit off and remove the wrap from the patient immediately.</p> <p>If the patient is utilizing a sterile wrap, the wound site may need to be cleaned. Consult a physician for proper wound care.</p> <p>Inspect the wrap for physical damage. If the wrap shows any signs of puncture or tear, the wrap should not be used. Discard the wrap and Contact ThermoTek Customer Support.</p>
	The wrap may be installed too tightly.	Stop compression therapy. Remove and reapply following Therapy Wrap instruction

Problem	Cause	Suggested Actions
The wrap is uncomfortable and/or is compressing too tightly. (cont'd on next page)	Internal fault within the therapy unit.	<p>Check the compression level on the display. Compression levels should never exceed 70 mm Hg.</p> <p>If the unit is displaying a pressure that exceeds these values for the therapies listed, stop compression immediately and contact customer support.</p>

Problem	Cause	Suggested Actions
The wrap is uncomfortable and/or is compressing too tightly.	The wrap is kinked	Check if wrap is kinked as to not allow the air from the wrap to deflate. Readjust or reapply wrap to alleviate the kink.

Problem	Cause	Suggested Actions
The wrap will not deflate	The unit is in Alarms Active state.	Check display for alarm events. If alarms are displayed use the troubleshooting guide to resolve the issue.
	Internal fault within the therapy unit.	Turn the power switch off, wait, and turn it back on. Contact ThermoTek customer service if problem persists.
	Inappropriate therapy selected.	Verify the mode prescribed is the mode currently active. See Chapter 9 for instructions on starting and stopping therapy modes. Allow appropriate amount of time for the unit to cool or heat. Depending on the therapy wrap prescribed, the wrap may take between 10 and 30 minutes to reach preset therapy temperature

Problem	Cause	Suggested Actions
The unit is heating when it should be cooling (or cooling when it should be heating)	Internal fault within the therapy unit.	Turn the power switch off, wait, and turn it back on. Contact ThermoTek customer service if problem persists.
	The unit is in Alarms Active state.	Check display for alarm events. If alarms are displayed use the troubleshooting guide to resolve the issue.

Problem	Cause	Suggested Actions
Unit turns on, but it is not heating or cooling. (cont'd on next page)	Heat / Cool therapy not selected.	Check the display to see if therapy mode is selected. . See Chapter 9 for instructions on starting and stopping therapy modes.

Problem	Cause	Suggested Actions
Unit turns on, but it is not heating or cooling.	Internal fault within the therapy unit.	Turn the power switch off, wait, and turn it back on. Contact ThermoTek customer service if problem persists
	Physical damage to unit.	Inspect the unit for physical damage. If the unit shows any cracks or dents, the unit should not be used. Contact ThermoTek Customer Support.

Problem	Cause	Suggested Actions
The unit is noisy.	Foreign objects lodged inside the air filter.	Turn the unit off and unplug it from the power source. Remove the air filter and inspect the chassis vents for any foreign objects that may be lodged inside or present in the unit. If the foreign object cannot be removed, Contact ThermoTek Customer Support.
	Internal fault within the therapy unit.	Turn the power switch off, wait, and turn it back on. Contact ThermoTek customer service if problem persists.
	Unit not connected to AC power.	Make sure the unit is connected to the AC outlet. Make sure the power switch on unit is switched to the ON position.

Problem	Cause	Suggested Actions
The display is not functioning. (cont'd on next page)	Physical damage to unit.	Inspect the unit for physical damage. If the unit shows any cracks or dents, the unit should not be used. Contact ThermoTek Customer Support.
	Internal fault within the therapy unit.	Turn the power switch off, wait, and turn it back on. Contact ThermoTek customer service if problem persists.

Problem	Cause	Suggested Actions
The display is not functioning.	Unit not connected to AC power	Make sure the unit is connected to the AC outlet. Make sure the power switch on unit is switched to the ON position.

Problem	Cause	Suggested Actions
The keypad is not responding	Physical damage to unit.	Inspect the unit for physical damage. If the unit shows any cracks or dents, the unit should not be used. Contact ThermoTek Customer Support.
	Internal fault within the therapy unit.	Turn the power switch off, wait, and turn it back on. Contact ThermoTek customer service if problem persists.

15. Device Summary

The VascuTherm Therapy System is capable of performing therapies for the following:

- **Cool Therapy:** the unit passes cool (43°F - 50°F) fluid through the wrap for the management of pain, discomfort and swelling. If prescribed, Cool therapy can be used in combination with Pneumatic Compression Therapy.
- **Heat Therapy:** the unit passes warm (105°F) fluid through the wrap for the management of pain and discomfort. If prescribed, Heat therapy can be used in combination with Pneumatic Compression Therapy.
- **Pneumatic Compression Therapy for Edema and Lymphedema:** the unit uses a preset cycle time to inflate compressed air into the therapy wrap. This added external pressure aids in reducing the pooling of blood and lymphatic fluid in the targeted extremity.
- **Pneumatic Compression Therapy to Reduce the Risk of DVT Formation:** the unit uses a preset cycle time to inflate compressed air into the therapy wrap. This action increases blood flow return through the veins of the lower extremities to the heart and reduce the risk of clot formation.

The wraps for the VascuTherm system are designed to maximize the effectiveness of the therapies listed above. Only use wraps in combination with therapy modes as prescribed.

Basic Instructions for Use:

The instructions listed here are not intended to replace the complete user instructions listed in Chapters 8 and 9. The user should read this entire manual before attempting to operate the device.

1. Attach the therapy wraps as described in the instructions located in the wrap packaging.
2. Prepare the unit for operation using the “How to Set-Up Your VascuTherm System for Therapy” instructions in Chapter 8.
3. Initiate the prescribed therapy of Heat, Cool or Thermal Contrast with or without Pneumatic Compression for the duration advised on the prescription.
4. Stop all therapy modes after the prescribed duration is complete.
5. If Pneumatic Compression was utilized, make sure to stop the compression therapy before removing the therapy wrap.

If you experience difficulty in setting up your VascuTherm therapy system for use, please contact the clinic or hospital that prescribed the unit or the Durable Medical Equipment (DME) provider. If assistance is not available or is ineffective, please contact ThermoTek technical assistance toll-free at 1-877-242-3232 during the hours of 8am-5pm Central Time. If technical assistance is needed after these hours, you may contact the 24-hour line at 214-502-8800.

16. Service and Customer Support

ThermoTek, Inc. is committed to servicing our VascuTherm™ unit both during and after sale to the customer. If you have any questions concerning the operation of your VascuTherm™ unit, please refer to the following to contact us at our Flower Mound, Texas facility:

- **Sales Organization:** (972) 874-4949
- **Toll Free Number:** (877) 242-3232
(between 8:00am and 5:00pm CST, Monday through Friday)
- **ThermoTek Website:** www.thermotekusa.com
- **Service Department** (after hours): (214) 502-8800



Do not drink or ingest the coolant mixture.

In the event of a Medical Emergency, call:

9-1-1

17. Wraps, Accessories and Replacement Parts

Boxes/Foam:

Part Number	Description
0P2HNTFSET	Packing Foam
0P2HNTSBX0	Shipping Box
0P9KNTCKS0	Traveling Case, Single

Replacement Parts:

Part Number	Description
0P2CDMARFT	Washable Air Filter
0P9PTDVTF A	Filter Assembly with Velcro loop
0P2DDMRSPG	Reservoir Cap
0P3WHG13PC	Cord, PW 10A/125 VAC, Hospital Grade, 12 ft.
0P2DNANTFB	Mixing Bottle, Thermoflow

Available Therapy Wraps:

Part Number	Description
0P9BNDVTFT	DVT Foot Wrap Set, Non-Sterile
0P9BNDVTCA	DVT Calf Wrap Set, Non-Sterile
* Sterile Therapy Wrap options available (example: 0P9XXXXXXXX3-S)	
0P9BSFKNMR3	Standard Knee Wrap, Single Patient Use
0P9BLFKNMR3	Medium Knee Wrap, Single Patient Use
0P9BKNEEMR3	Large Knee Wrap, Single Patient Use
0P9BSFNCMR3	Knee Wrap w/o compression, Single Patient Use
0P9BUKNEMR3	Universal U Wrap, Single Patient Use
0P9BSSHLMR3	Standard Shoulder Wrap, Single Patient Use
0P9BMSHDMR3	Medium Shoulder Wrap, Single Patient Use
0P9BSHLDMR3	Large Shoulder Wrap, Single Patient Use
0P9BLARMMR3	Arm Wrap, Single Patient Use
0P9BFARMMR3	Full Arm Wrap, Single Patient Use
0P9BFTAKMR3	Foot/Ankle Wrap, Single Patient Use
0P9BHPLBMR3	Hip Wrap, Single Patient Use
0P9BBACKMR3	Back Wrap, Single Patient Use
0P9BUCRVMR3	Upper Cervical Wrap, Single Patient Use
0P9BLCRVMR3	Lower Cervical Wrap, Single Patient Use
0P9BTCRVMR3	Total Cervical Wrap, Single Patient Use
0P9BMNWAMR3	Mini Wrap, Single Patient Use
0P9BMNNAMR3	Mini Wrap, No Compression, Single Patient Use
0P9BFACEMR3	Face Wrap, Single Patient Use
0P9BHEADMR3	Head Wrap, Single Patient Use

Hose Assemblies:

Part Number	Description
0P9ANANUMB	Hose, Therapy Umbilical, Standard 7 ft.

Optional Equipment:

Part Number	Description
0P9KNVPMKT	Kit, Unit Pole Mount, Nano/Vascu

18. Specifications

VascuTherm Part Number	0P9PTVASCU
Dimensions	5.25”W x 8.75”H x 14.25”D
Ambient Operating Range	60 – 80 °F
Relative Humidity	< 60% RH
Therapy Temperature Range	43 – 105 °F
Centrifugal Pump	12-volt Brushless DC
Weight without Fluid	15-pounds
System Fluid Capacity	32-ounces
Power Consumption (Max)	450 Watts
Input Voltage (Nominal)	100-120 VAC, 60 Hz, Single Phase
Input Current (Max)	4.5 Amps
Accuracy	± 2 °F
Refrigerant	None
Heating/Cooling Function	Yes, Standard
RS232 Interface	Yes, Standard
Recommended Coolants	90% distilled water, 10% alcohol

18.1 Calibration

The VascuTherm therapy unit is comprised of components that are of high accuracy and low drift. Under normal operation, the therapy unit does not require calibration. The end user has the option to send the unit to ThermoTek for calibration or request documentation from the factory, which details the calibration steps.

18.2 Product Listing



The VascuTherm therapy unit has been tested and listed by ETL to meet or exceed the requirements for UL Medical Listing 60601 Standards. This product is classified as a Type B Medical Equipment, Class II



ThermoTek is a registered medical equipment manufacturer with The United States Food and Drug Administration (FDA).

19. Index

A

Alarms:
 System Display, 10-2
Automatic Therapy, 9-1

B

Beeping,
 Alarms and Warning, 10-2

C

Calf Therapy, 9-15, 10-1
Cautions for Use, 3-3
Contraindications, 2-1, 3-1

D

Deep Venous Thrombosis (DVT), 2-1,
 3-1, 4-1
 Calf Therapy, 9-15, 10-1
 Foot Therapy, 9-6, 10-1
 Glossary, 2-1
Draining, 12-1

E

Edema, 2-1, 3-1, 4-1, 8-1, 9-1, 15-1
Environment,
 Operation, 3-2, 5-1, 7-1, 9-1
 Storage, 13-1
 Troubleshooting, 14-1

F

Filling,
 Fluid Reservoir, 3-2, 5-2, 5-3, 14-2

I

Indications for Use, 2-1, 4-1

L

Lymphedema, 4-1, 5-1, 8-1, 9-1, 9-7,
 14-2, 15-1

M

Maintenance,
 Cleaning, 11-1

P

Precautions for Use, 3-2
Programmed Therapy, 9-1

R

Re-packaging, 13-1

S

Setup, 8-1
Startup, 9-1
Storage, 13-1
Support, 1-1, 8-3, 10-4, 14-1, 16-1
System Error, 10-2

T

Therapy:
 Starting:
 Calf DVT, 9-15
 Compression, 9-9
 Cool, 9-3
 Foot DVT, 9-12
 Heat, 9-5
 Stopping:
 Calf DVT, 9-17
 Compression, 9-10
 Cool, 9-4
 Foot DVT, 9-14
 Heat, 9-5

Timer, 9-1

Troubleshooting, 14-1

W

Warning,
 For Use, 3-2
 see also Precautions for Use *and*
 Cautions for Use)
 System Display, 10-2

20. Warranty and Disclaimer Information

ThermoTek Inc. warrants for twelve months from the date of shipment to the end user, any ThermoTek VascuTherm™ unit according to the following terms:

All parts of the unit manufactured or supplied by ThermoTek Inc. shall be free from defects in material and workmanship for a period of one year from the date of shipment. ThermoTek Inc. shall repair or exchange the product within the warranty period when the unit has been found in the reasonable judgment of ThermoTek to have defective material or workmanship. The unit must be returned to an authorized ThermoTek Service Center. The buyer shall pay for the expense of returning the unit to the authorized ThermoTek Service Center for warranty service. ThermoTek Inc. will pay for the expense of returning the unit back to the buyer. Return units must be in the ThermoTek approved box and packing material to ensure safe transport. Removal of the warranty seals or other attempts of servicing the inside of the unit shall void this warranty.

The buyer shall be responsible and assessed a fee for test and calibration if no defects are found with the ThermoTek product.

In the event that the product or any portion thereof is not installed or used in accordance with the manufacturer's Operating Instructions, any and all warranties either expressed or implied shall be and are hereby voided. Only upon the proper installation and use of the items shall this warranty apply. This warranty does not cover any unit that has been altered or modified so as to change its intended use. In addition, this warranty does not extend to the use of parts, accessories, or fluids which are either incompatible with the unit or adversely affect its operation, performance, or durability.

Because ThermoTek Inc. constantly provides our customers with the latest technology, we reserve the right to change or improve the design of any unit without assuming any obligation to modify any unit previously manufactured.

All units returned for warranty claims must have a Returned Materials Authorization (herein referred to as RMA) number on the outside of the container. Please call ThermoTek Customer Service at 972-242-3232 for an RMA number. Before returning a system to the factory, it must be drained of all fluids and packed in the original packaging.

In order to quickly process your warranty repair request, your customer service representative will require the following information about your system:

- Model Number
- Serial Number
- Description of Problem
- Contact Name and Phone Number

This information is on the serial plate located on the back side of the unit.

DISCLAIMER

THE INFORMATION CONTAINED IN THIS DOCUMENT IS PROVIDED "AS IS". THERMOTEK EXPRESSLY DISCLAIMS ALL INFORMATION INCLUDING, BUT NOT LIMITED TO, EXPRESS AND IMPLIED WARRANTIES OF MERCHANTABILITY, FITNESS FOR A PARTICULAR USE, OR NON-INFRINGEMENT. IN NO EVENT WILL THERMOTEK BE LIABLE FOR ANY DIRECT, INDIRECT, SPECIAL, INCIDENTAL OR CONSEQUENTIAL DAMAGES, INCLUDING LOST PROFITS, LOST BUSINESS OR LOST DATA, RESULTING FROM THE USE OF OR RELIANCE UPON THE INFORMATION, WHETHER OR NOT THERMOTEK HAS BEEN ADVISED OF THE POSSIBILITY OF SUCH DAMAGES.

ThermoTek Inc. assumes no responsibility for the accuracy or completeness of the information presented which is subject to change without notice. Mention of non-ThermoTek products or services is for information purposes only and constitutes neither an endorsement nor a recommendation.